

Innovative Playgrounds Company, Inc
 12407 E. Slauson Ave. Unit D
 Whittier, CA 90606
 Ph: (562) 693-5200
 Fax: (562) 693-5199
 www.innovplay.com



Estimate

Date	Estimate #
6/16/2022	10270
Rep	MW

Bill To:
Wrightwood Community Services District 1275 Highway 2 Wrightwood, CA 92397 SOURCEWELL MEMBER ID# 216421

Ship To:	
Hollis M. Stewart Children's Park 6059 Pine St. Wrightwood, CA 92397	
Job Name:	Hollis Stewart Children's Park - 5 Areas

Item	Description	Total
DEMO	**Area 1** Demo and Dispose of Existing Playground Equipment and Table. (Open Market)	11,528.17
PREP WORK	Push Back Approx. (2,300) SF of Existing Woodchips at 12" Depth and Re-install Upon Completion. (Open Market)	5,507.04
PLAY UNIT	Supply Burke Play Equipment as Per Drawing #513-136825-6 Includes (1) Burke 5' OD Triple Bay Single Post Frame Swing at 8' Toprail with (4) Belt Seats, (1) Freedom ADA Seat, (1) Konnection Seat with Chains, (1) 4 Seat Rocker, (1) 8' Traditional Series Bench with Back - In Ground Mount, (2) 8' Traditional Series Picnic Tables - Portable, and (2) Welcome Age Signs. LIST PRICE \$15,599.00 *SOURCEWELL CUSTOMER DISCOUNT* APPLIED (\$2,339.85) (Burke Sourcewell Contract # 010521-BUR)	13,259.15T
INSTALLATION	Install Burke Play Equipment as Per Drawing #513-136825-6, Includes (1) Burke 5' OD Triple Bay Single Post Frame Swing at 8' Toprail with (4) Belt Seats, (1) Freedom ADA Seat, (1) Konnection Seat with Chains, (1) 4 Seat Rocker, (1) 8' Traditional Series Bench with Back - In Ground Mount, (2) 8' Traditional Series Picnic Tables - Portable, and (2) Welcome Age Signs into Dirt.	8,063.38
PREP WORK	**Area 2** Push Back Approx. (1,108) SF of Existing Woodchips at 18" Depth and Re-install Upon Completion. (Open Market)	3,979.44

PAYMENT TERMS - PRODUCT with INSTALLATION PROJECTS:

Provide a check for 50% of the entire project at time of order.
 Provide a check for 25% of the entire project upon delivery.
 Provide a check for the remaining 25% at the completion of the project.

PAYMENT TERMS - PRODUCT ONLY PROJECTS:

Provide a check for 50% of the entire estimate at time of order.
 Provide a check for remaining 50% prior to order shipping from manufacturer.
 For estimates under \$5,000, provide a check for 100% of the entire project at time of order.
NET 30 ON PO'S FROM CITIES, SCHOOL DISTRICTS, STATE, OR FEDERAL ENTITIES
 Sales Tax will be reflected as of date of invoice

Subtotal

Sales Tax (7.75%)

Total

ESTIMATE VALID FOR 30 DAYS

Acceptance of Estimate. The above prices, specifications and conditions are satisfactory and are hereby accepted. Any alterations or deviations from the above will be accepted only upon written notice and will become an extra charge over and above the estimate period. Shipping and/or installation dates are 8-10 weeks from acceptance date. Invoices will be issued upon shipment of product or start of installation services. Balance of deposit due as per payment terms.

Accepted By:

Innovative Playgrounds Company, Inc
 12407 E. Slauson Ave. Unit D
 Whittier, CA 90606
 Ph: (562) 693-5200
 Fax: (562) 693-5199
 www.innovplay.com



Estimate

Date	Estimate #
6/16/2022	10270
Rep	MW

Bill To:
Wrightwood Community Services District 1275 Highway 2 Wrightwood, CA 92397 SOURCEWELL MEMBER ID# 216421

Ship To:	
Hollis M. Stewart Children's Park 6059 Pine St. Wrightwood, CA 92397	
Job Name:	Hollis Stewart Children's Park - 5 Areas

Item	Description	Total
PLAY UNIT	Supply Burke Play Equipment as Per Drawing #513-136830-5, Includes (1) "Nature Play Series" Large Boulder, and (1) "Nature Play Series" Rock Climber for 5-12 Age Group. LIST PRICE \$37,950.00 *SOURCEWELL CUSTOMER DISCOUNT* APPLIED (\$5,692.50) (Burke Sourcewell Contract # 010521-BUR)	32,257.50T
INSTALLATION	Install Burke Play Equipment as Per Drawing #513-136830-5, Includes (1) "Nature Play Series" Large Boulder, and (1) "Nature Play Series" Rock Climber for 5-12 Age Group into Dirt. ** Area 3**	16,126.76
PREP WORK	Push Back Approx. (1,657) SF of Existing Woodchips at 18" Depth and Re-install Upon Completion. (Open Market)	5,951.20
PLAY UNIT	Supply Burke Play Equipment as Per Drawing #513-136831-5 Includes (1) "RopeVenture Series" Revolve Climber for 5-12 Age Group, and (1) Spinetic Spinner for 5-12 Age Group. LIST PRICE \$50,762.00 *SOURCEWELL CUSTOMER DISCOUNT* APPLIED (\$7,614.30) (Burke Sourcewell Contract # 010521-BUR)	43,147.70T
INSTALLATION	Install Burke Play Equipment as Per Drawing #513-136831-5, Includes (1) "RopeVenture Series" Revolve Climber for 5-12 Age Group, and (1) Spinetic Spinner for 5-12 Age Group into Dirt. **Area 4**	18,873.24
DEMO	Demo and Dispose of Existing Table. (Open Market)	704.23

PAYMENT TERMS - PRODUCT with INSTALLATION PROJECTS:
 Provide a check for 50% of the entire project at time of order.
 Provide a check for 25% of the entire project upon delivery.
 Provide a check for the remaining 25% at the completion of the project.
PAYMENT TERMS - PRODUCT ONLY PROJECTS:
 Provide a check for 50% of the entire estimate at time of order.
 Provide a check for remaining 50% prior to order shipping from manufacturer.
 For estimates under \$5,000, provide a check for 100% of the entire project at time of order.
 NET 30 ON PO'S FROM CITIES, SCHOOL DISTRICTS, STATE, OR FEDERAL ENTITIES
 Sales Tax will be reflected as of date of invoice

Subtotal
Sales Tax (7.75%)
Total

ESTIMATE VALID FOR 30 DAYS
 Acceptance of Estimate. The above prices, specifications and conditions are satisfactory and are hereby accepted. Any alterations or deviations from the above will be accepted only upon written notice and will become an extra charge over and above the estimate period. Shipping and/or installation dates are 8-10 weeks from acceptance date. Invoices will be issued upon shipment of product or start of installation services. Balance of deposit due as per payment terms.

Accepted By:

Innovative Playgrounds Company, Inc
 12407 E. Slauson Ave. Unit D
 Whittier, CA 90606
 Ph: (562) 693-5200
 Fax: (562) 693-5199
 www.innovplay.com



Estimate

Date	Estimate #
6/16/2022	10270
Rep	MW

Bill To:
Wrightwood Community Services District 1275 Highway 2 Wrightwood, CA 92397 SOURCEWELL MEMBER ID# 216421

Ship To:	
Hollis M. Stewart Children's Park 6059 Pine St. Wrightwood, CA 92397	
Job Name:	Hollis Stewart Children's Park - 5 Areas

Item	Description	Total
INSTALLATION	Relocate (2) Existing Concrete Benches and (1) Metal Trash Can to Outside of the New Play Area Layout (Few Feet Away). (Open Market)	1,408.45
PREP WORK	Remove Approx. (720) SF of Existing Woodchips at 4" Depth and Spread Around Outside of New Play Area Layout. (Open Market)	1,216.90
PREP WORK	Construct Approx. 106' Long x 6" Wide x 18" Deep Concrete Curbing. (Open Market)	6,718.31
PREP WORK	Install (720) SF of Weedblock Fabric for New Layout. (Open Market)	1,440.85
PLAY UNIT	Supply Burke Play Equipment as Per Drawing #513-136832-6, Includes (1) "Synergy Series" Unit for 2-5 Age Group with 3.5" OD Aluminum Posts, (2) 8' Traditional Series Bench with Back - In Ground Mount, and (1) 8' Traditional Series Picnic Tables - Portable. LIST PRICE \$25,508.00 "SOURCEWELL CUSTOMER DISCOUNT" APPLIED (\$3,826.20) (Burke Sourcewell Contract # 010521-BUR)	21,681.80T
KIT-2	FREE Maintenance Kit (Includes Installation Booklet, Graffiti Remover, Tools and Touch Up Paint). LIST PRICE \$250.00	0.00T
KIT-3	FREE NPPS Safety and Supervision Kit (Includes Infrared Thermometer, Supervision Safety Booklet and Safety Pack). LIST PRICE: \$250.00	0.00T
INSTALLATION	Install Burke Play Equipment as Per Drawing #513-136832-6, Includes (1) "Synergy Series" Unit for 2-5 Age Group with 3.5" OD Aluminum Posts, (2) 8' Traditional Series Bench with Back - In Ground Mount, and (1) 8' Traditional Series Picnic Tables - Portable into Dirt.	15,316.90

PAYMENT TERMS - PRODUCT with INSTALLATION PROJECTS:
 Provide a check for 50% of the entire project at time of order.
 Provide a check for 25% of the entire project upon delivery.
 Provide a check for the remaining 25% at the completion of the project.

PAYMENT TERMS - PRODUCT ONLY PROJECTS:
 Provide a check for 50% of the entire estimate at time of order.
 Provide a check for remaining 50% prior to order shipping from manufacturer.
 For estimates under \$5,000, provide a check for 100% of the entire project at time of order.
 NET 30 ON PO'S FROM CITIES, SCHOOL DISTRICTS, STATE, OR FEDERAL ENTITIES
 Sales Tax will be reflected as of date of invoice

Subtotal
Sales Tax (7.75%)
Total

ESTIMATE VALID FOR 30 DAYS
 Acceptance of Estimate: The above prices, specifications and conditions are satisfactory and are hereby accepted. Any alterations or deviations from the above will be accepted only upon written notice and will become an extra charge over and above the estimate period. Shipping and/or installation dates are 8-10 weeks from acceptance date. Invoices will be issued upon shipment of product or start of installation services. Balance of deposit due as per payment terms.

Accepted By: _____

Innovative Playgrounds Company, Inc
 12407 E. Slauson Ave. Unit D
 Whittier, CA 90606
 Ph: (562) 693-5200
 Fax: (562) 693-5199
 www.innovplay.com



Estimate

Date	Estimate #
6/16/2022	10270
Rep	MW

Bill To:
Wrightwood Community Services District 1275 Highway 2 Wrightwood, CA 92397 SOURCEWELL MEMBER ID# 216421

Ship To:	
Hollis M. Stewart Children's Park 6059 Pine St. Wrightwood, CA 92397	
Job Name:	Hollis Stewart Children's Park - 5 Areas

Item	Description	Total
DEMO	**Area 5** Demo and Dispose of (1) Existing Table, and (55) LF of Railroad Ties. (Open Market)	1,866.20
PREP WORK	Remove Approx. (1,144) SF of Existing Woodchips at 4" Depth and Spread Around Outside of New Play Area Layout. (Open Market)	1,933.52
PREP WORK	Excavate Approx. (792) SF of Dirt at 6" Depth and Compact in One Section of Area. (Open Market)	3,067.61
PREP WORK	Construct Approx. 89' Long x 6" Wide x 18" Deep Concrete Curbing to Connect to Existing Concrete Curb in Area 3. (Open Market)	10,901.41
	Construct 83' Long x 6" Wide x 18" Deep Concrete Curbing for Adjacent Area. (Open Market)	
PREP WORK	Install (1,144) SF of Weedblock Fabric for New Layouts. (Open Market)	2,528.87
PLAY UNIT	Supply Burke Play Equipment as Per Drawing #513-138024-7, Includes (1) Freestanding Triple Viper Slide for 5-12 Age Group with 5" OD Aluminum Posts, (1) 12' Single Beam Kid Koaster, and (2) 8' Traditional Series Picnic Tables - Portable. LIST PRICE \$23,072.00	19,611.20T
	SOURCEWELL CUSTOMER DISCOUNT APPLIED (\$3,460.80) (Burke Sourcewell Contract # 010521-BUR)	
KIT-2	FREE Maintenance Kit (Includes Installation Booklet, Graffiti Remover, Tools and Touch Up Paint). LIST PRICE \$250.00	0.00T

PAYMENT TERMS - PRODUCT with INSTALLATION PROJECTS:
 Provide a check for 50% of the entire project at time of order.
 Provide a check for 25% of the entire project upon delivery.
 Provide a check for the remaining 25% at the completion of the project.
PAYMENT TERMS - PRODUCT ONLY PROJECTS:
 Provide a check for 50% of the entire estimate at time of order.
 Provide a check for remaining 50% prior to order shipping from manufacturer.
 For estimates under \$5,000, provide a check for 100% of the entire project at time of order.
 NET 30 ON PO'S FROM CITIES, SCHOOL DISTRICTS, STATE, OR FEDERAL ENTITIES
 Sales Tax will be reflected as of date of invoice

Subtotal
Sales Tax (7.75%)
Total

ESTIMATE VALID FOR 30 DAYS
 Acceptance of Estimate. The above prices, specifications and conditions are satisfactory and are hereby accepted. Any alterations or deviations from the above will be accepted only upon written notice and will become an extra charge over and above the estimate period. Shipping and/or installation dates are 8-10 weeks from acceptance date. Invoices will be issued upon shipment of product or start of installation services. Balance of deposit due as per payment terms.

Accepted By: _____

Innovative Playgrounds Company, Inc
 12407 E. Slauson Ave. Unit D
 Whittier, CA 90606
 Ph: (562) 693-5200
 Fax: (562) 693-5199
 www.innovplay.com



Estimate

Date	Estimate #
6/16/2022	10270
Rep	MW

Bill To:
Wrightwood Community Services District 1275 Highway 2 Wrightwood, CA 92397 SOURCEWELL MEMBER ID# 216421

Ship To:	
Hollis M. Stewart Children's Park 6059 Pine St. Wrightwood, CA 92397	
Job Name:	Hollis Stewart Children's Park - 5 Areas

Item	Description	Total
INSTALLATION	Install Burke Play Equipment as Per Drawing #513-138024-7, Includes (1) Freestanding Triple Viper Slide for 5-12 Age Group with 5" OD Aluminum Posts, (1) 12' Single Beam Kid Koaster, and (2) 8' Traditional Series Picnic Tables - Portable into Dirt.	13,274.65
TEMP. FENCING	Provide (300) LF of Temporary Fencing During Installation of Play Equipment and Play Area Surfacing. (Open Market)	2,535.21
FREIGHT	Burke Shipping Charge to CA. Freight Price Valid for 30 Days Only, Due to Fluctuating Fuel Pricing. Please Requote After 7/16/22.	9,812.00
FREIGHT	Receive/Offload All Equipment with Forklift at Innovative Yard and Redeliver as Needed Throughout Installation to Wrightwood, CA. (Open Market)	1,220.00
WARRANTY	LONGEST AND STRONGEST WARRANTY, INCLUDING UV-20 PROTECTION ON PLASTICS.	0.00
BONDS	PAYMENT BOND & PERFORMANCE BOND FEE (3% of Total: \$284,003.37).	8,520.10
INCLUDES	Pricing includes prevailing wage rates.	0.00
EXCLUDES	Pricing excludes regular wage rates, permits, any border material and/or concrete curbing, safety surfacing, fencing (temp or permanent), special installation due to unforeseen site conditions and any additional site work/preparation/amenities.	0.00

PAYMENT TERMS - PRODUCT with INSTALLATION PROJECTS:
 Provide a check for 50% of the entire project at time of order.
 Provide a check for 25% of the entire project upon delivery.
 Provide a check for the remaining 25% at the completion of the project.
PAYMENT TERMS - PRODUCT ONLY PROJECTS:
 Provide a check for 50% of the entire estimate at time of order.
 Provide a check for remaining 50% prior to order shipping from manufacturer.
 For estimates under \$5,000, provide a check for 100% of the entire project at time of order.
NET 30 ON PO'S FROM CITIES, SCHOOL DISTRICTS, STATE, OR FEDERAL ENTITIES
 Sales Tax will be reflected as of date of invoice

Subtotal	\$282,451.79
Sales Tax (7.75%)	\$10,071.70
Total	\$292,523.49

ESTIMATE VALID FOR 30 DAYS
 Acceptance of Estimate. The above prices, specifications and conditions are satisfactory and are hereby accepted. Any alterations or deviations from the above will be accepted only upon written notice and will become an extra charge over and above the estimate period. Shipping and/or installation dates are 8-10 weeks from acceptance date. Invoices will be issued upon shipment of product or start of installation services. Balance of deposit due as per payment terms.

Accepted By:



Innovative PLAYGROUNDS CO.

Proud Representative of

Burke

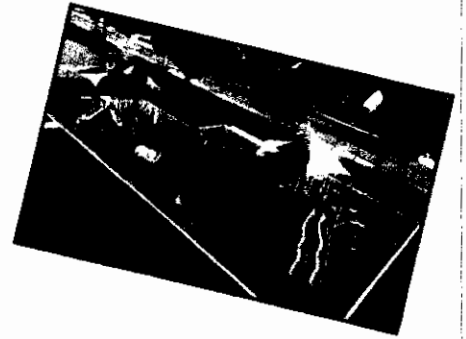

Our Business Philosophy:

Our team at Innovative Playgrounds Company brings over 40 years of combined commercial playground sales and construction experience in the park, recreation, school, and childcare industry. We are a well established and professional representative firm serving California for some of the most prestigious manufacturers around the country. As a full turn-key service company, we are able to offer FREE site assessments, design consultations, funding resources, and project management for playground and fitness equipment, safety surfacing, shade structures, sport and site amenities. Innovative Playgrounds is not about selling you playground equipment today, but developing a lasting partnership for tomorrow. We are committed to making a difference in the lives of children by providing safe, fun, and quality playground equipment. We build on providing first class service by establishing relationships that demonstrate what we believe in: customer trust. Most of all, we are dedicated to changing every community we are involved with by impacting the development of our children and their future.

We Believe in Generations of Play!

INNOVATIVE PLAYGROUNDS ADDED-VALUES

- Full turn-key service company (site assessments, designs, funding resources, and project management for playground/fitness equipment, safety surfacing, shade structures, and sport/site amenities)
- 2D drawings, color and custom 3-Ds and plan views provided to you at no cost
- Free Maintenance and NPPS Supervision Kits provided with every playground purchase
- Seminars offered on playground safety
- Represent only nationally recognized manufacturers
- BCI Burke, our flagship playground equipment manufacturer has the highest quality products, the longest and strongest non-prorated WARRANTY in the industry
 - Established in 1920 BCI Burke is the oldest playground equipment manufacturer in the country
 - Founding and active member of IPEMA (International Playground Equipment Manufacturers Association)
 - Burke's track record for shipments averages well over 95% complete, correct and on time since 2002
 - Industry leading order turn-around time. Orders leave our docks approximately four weeks from the time we receive a complete order
- Solid relationship with local certified playground equipment installers
- With Burke, we offer California Multiple Award Schedule (CMAS) Contracts and General Services Administration (GSA) Contracts as well as other nationally recognized purchasing contracts for qualified customers such as NIPA and AFNAFPO. Contact us to learn more.
- Offer Exclusive Burke "Funds for Fun" fundraising assistance program, a "Grant Resource Center", and finance options, and assistance with KaBOOM!
- Products meet or exceed Consumer Product Safety Commission (CPSC) & ASTM standards
- BCI Burke equipment is International Playgrounds Equipment Manufacturers Association (IPEMA) Certified as shown on IPEMA's web site (ipema.org)
- All of our equipment is designed to comply with Americans with Disabilities Act Accessibility Guidelines (ADAAG)
- Service and Maintenance Warranties available
- Member of California Park and Recreation Society and Southern California Municipal Athletic Federation (SCMAF)



Call Us Today Toll Free At
1-877-732-5200



PLAY THAT MOVES YOU[®]

At Burke, movement is our mantra. It drives our purpose and ignites our passion to bring the best in playground design and the most innovative, developmentally rich play, outdoor fitness and recreation products. Our research and testing push us to create new and unique ways to challenge children, families, schools, communities, teams and individuals to move, to grow and to play. Play fosters opportunities for connection between generations and with our peers, provides growth and togetherness and moves us in so many ways. Join Our Movement[™] and experience the many ways play can move you.

PLAY FOR HEALTH

Movement is life and is one of the most important aspects in overall health and wellness for people of all ages and abilities. Burke has playground and fitness offerings that engage everyone in all stages of life to move. Our Nucleus[®] and Intensity[®] playgrounds feature a fusion of play that helps children engage in active play throughout the day for enhanced growth and developmental opportunities. ELEVATE[®] Fitness Course brings obstacle course fitness to a whole new level and is poised to engage children 5-12, teenagers and adults. ACTIVATE[®] Fitness Circuit and INVIGORATE[®] Dynamic Fitness are a great way to add events to a fitness trail or create a space for outdoor exercise. Our variety of fitness equipment will meet you where you are in your fitness journey and challenge you to be more.

PLAY FOR YOUR MIND

Playful experiences are learning experiences and children at play are developing a wide-variety of skills that range from problem solving and cognitive planning to memory and self-regulation. Each and every time a child plays they are contributing positively to their cognitive development and setting themselves up for future success.



PLAY FOR CONNECTION

Play provides us with common experiences, shared laughter and true connection. It brings communities together and helps us return to the simplicity of basic human connection and kindness. Parks and recreation spaces are critical because they lay the groundwork for the intergenerational engagement, interaction and development we all seek. Products such as Novo[®] Playful Furniture, with interesting pieces that can be used in a variety of ways, foster those opportunities by creating a space where everyone can interact and play together in their own way. The Konnection[®] Swing revolutionizes connection by promoting face-to-face connections and playing together. Every person of every age and ability brings their own unique experiences that enhance the collective and moves us all through play.

PLAY FOR MOTION

Motion play creates a childhood experience like no other by creating movement for children of all abilities and providing developmental benefits, including increased spatial awareness, inner ear stimulation and balance. Motion can be a source of calm for children with sensory processing differences while providing delight and excitement for children of all ages.

PLAY FOR DEVELOPMENT

Play is the work of childhood and helps children express themselves, monitor their emotions and develop a sense of identity that fuels their self-esteem and shapes their world view. Creating environments that foster this growth is at the heart of what we do at Burke and helps to teach resiliency and perseverance, all skills that transcend the playground and help children to develop into successful and healthy adults.

WORK THAT MOVES US

Our mission is simple – to bring Play That Moves You® to communities around the world. This mission drives us each and every day to innovate the best in play, playgrounds, recreation and outdoor fitness equipment that help everyone find the best of themselves through play. We are passionate about our legacy of customer service and craftsmanship while looking to the future and always striving to be better.

At Burke, play inspires us to create a community of people that are invested in growth, aren't afraid to commit to positive change and seek to enrich and enhance the lives of the people in communities where we serve and live. Researching, innovating and creating products that help communities and people grow and thrive is the core of our purpose. In our own community, we partner with organizations such as the YMCA and Boys and Girls Club of Fond du Lac and we support, on a larger scale, organizations, municipalities, schools, churches and associations to Join Our Movement® and help let play lead the way for change. This is work that moves us and we hope the results move you.

HANDCRAFTED IN AMERICA'S HEARTLAND

Walk through our Fond du Lac, WI manufacturing facility and you will see playgrounds coming to life through the hands of our people. In the age of assembly lines, we work to combine efficiency with a personal touch that makes every playground special. Bringing quality playgrounds to communities like yours is Work That Moves Us, and we hope the playgrounds we make move you too.

SUPERIOR SERVICE

Customer Service is a hallmark of Burke and we take pride in the fact that when you call, we answer. We have factory-direct customer service representatives that are available to answer questions, help with replacement parts or field inquiries about installations.

YOUR BURKE REPRESENTATIVE

We as Burke Representatives are passionate about bringing play to your community and helping you design your perfect play environment! We are knowledgeable and experienced about the entire playground process from site evaluation to design to maintenance and will work with you beyond installation to make sure your playground is, and remains, all you dreamed!



BURKE'S HISTORY

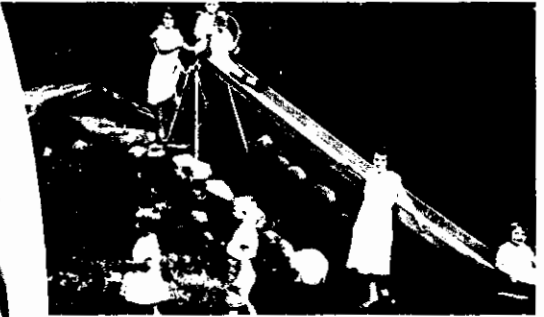

MORE THAN A CENTURY OF PLAY

Guided by our legacy of innovation, customer service and creativity, we are making the very best and most innovative playground, outdoor fitness and recreation products in our history! Our founder J.E. Burke set the course more than a century ago and we're taking his vision and making it even bigger! Through research, analysis and continuous improvement, we're designing products and playspaces that bring Play That Moves You[®] to communities for more fun, movement, engagement and development! Play is our passion, our mission and our business and we can't wait for you to Join Our Movement.

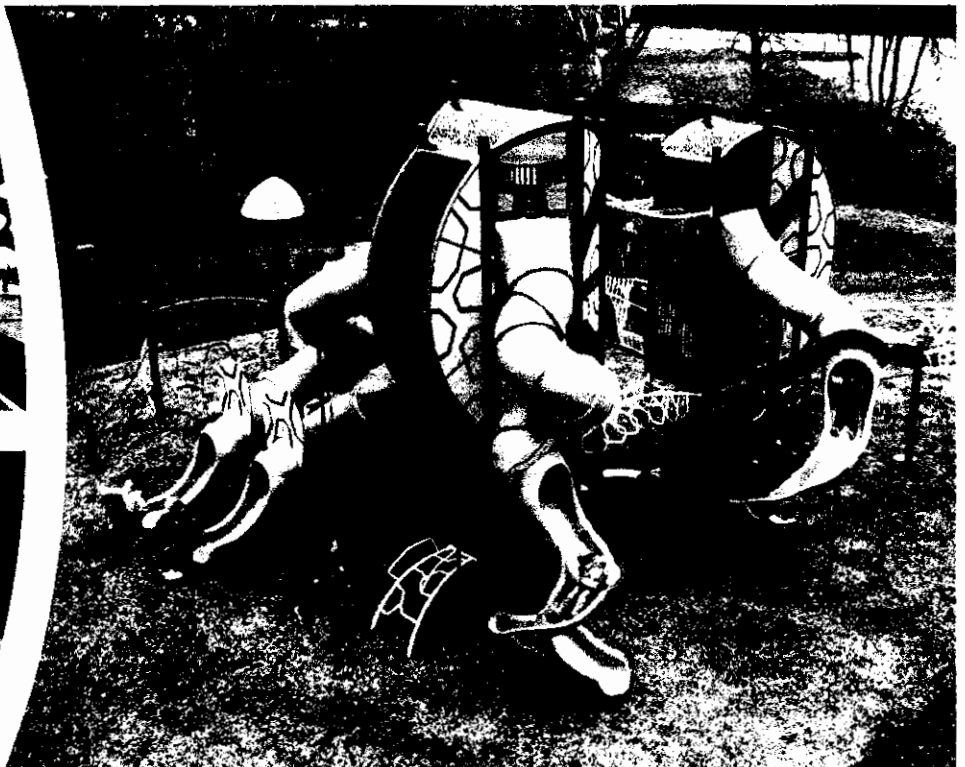

BURKE BUILT QUALITY

Discover the value of investing in a Burke Playground:

KOREKONNECT® DIRECT-BOLT CLAMP SYSTEM:

Nucleus® features our industry-leading KoreKonnnect direct-bolt clamp system resulting in the strongest and most accurate connection system ever. Factory located connection points make for easy, precise installation and an error-free fit. Best of all, KoreKonnnect is covered for 100 years under our non-prorated Generations Warranty®.

DIRECT-BOLT CONNECTION SYSTEM:

Intensity®, ELEVATE® Fitness Course, ACTIVATE® Fitness Circuit and Synergy® feature Burke's trusted direct-bolt connection that uses a durable, straightforward direct-bolt system to ensure a trouble-free installation and provide the necessary strength to accommodate the demands of playing children. Like our KoreKonnnect system, Direct-Bolt connections are covered for 100 years under our Generations Warranty.

EZKONNECT® DECK MOUNTING SYSTEM:

Our exclusive self-leveling deck attachment and factory CNC construction allows for faster and more precise location of decks during installation. The 2-bolt per corner deck attachment increases overall structure strength and stability.

PLATFORMS:

Burke's oversized non-slip platforms are constructed of heavy-duty punched steel that can support more than 2 tons. Our vinyl coating is California compliant, free of lead and other hazardous heavy metals.

TAMPER-RESISTANT STAINLESS STEEL HARDWARE:

All hardware is covered for 100 years under our Generations Warranty.

PREMIUM POWDER COATINGS:

Our industry-leading powder coatings and finishes prevent fading, last longer and deter rust. We also offer a "coastal package" powder coat system. This special powder coat system for metal components and upright posts will provide additional corrosion and chemical protection along with added longevity to the color and gloss retention of the powder coated parts. Contact your Burke Representative for more information on colors, price and warranty.

COMPOUND PLASTICS WITH UV-20:

You'll get long wear and bright, vibrant colors that hold up for years thanks to our thick, durable rotomolded plastics with UV-20 protection. This is why we can cover them for 15 years under our non-prorated Generations Warranty.

CLIMBING CABLES:

Our climbing cables are flexible enough to provide movement, yet strong enough to last. Our ropes are made from 6 polyester cords with steel reinforcement wrapped around a synthetic fiber core. Each cord contains 8 galvanized steel strands tightly covered with polyester multi-fibers. Our RopeVenture® cables consist of 6 strands, each containing 24 stainless steel reinforcing strands within a nylon sleeve, wrapped around a solid nylon core.

ALUMINUM CONNECTORS:

Swivel connectors at the end of our ropes allow assembly at any angle with no unwanted twists in the net. The aluminum fittings used to secure the joints are swaged in place to prevent any movement between the rope and fittings that could cause wear.

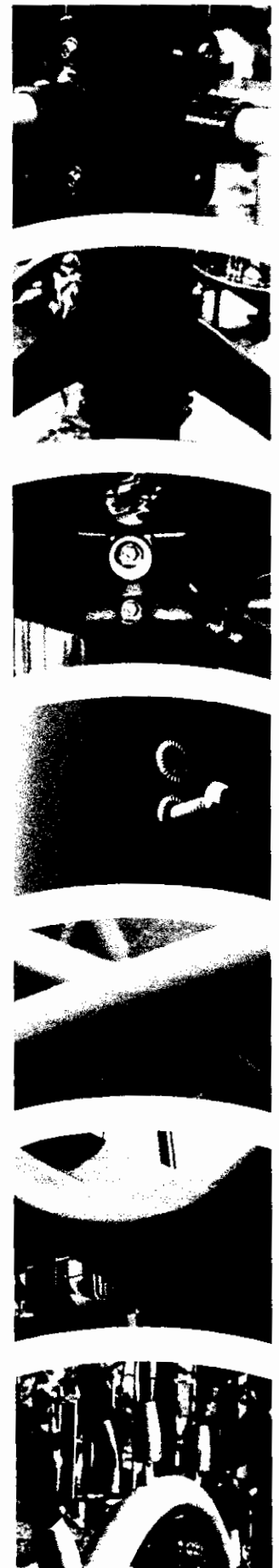

FREE RESOURCES

NPPS SAFETY KIT

Burke truly gives you the most value for your money. As part of our Total Cost of Ownership Package, we offer value-added resources FREE with every playground structure purchase. The National Program for Playground Safety (NPPS) Playground Supervision Safety Kit helps supervisors and educators be prepared on the playground. Learn more at bciburke.com/safety.

CUSTOM MAINTENANCE KIT

To help maintain a safe, functioning playground we include a custom maintenance schedule, touch-up paint, graffiti remover and carrying case FREE with every playground structure purchase.

PLANNING & FUNDING TOOLS

We provide you with FREE tools to plan your playground from fundraising and design to installing a community build playground. At Burke, we understand the dedication and hard work it takes to raise the funds for playground equipment. That's why we created Funds for Fun, a direct donation fundraising program to help your organization raise the funds it needs for your new playground. We've also partnered with The School Funding Center to provide up-to-date grant information along with expert grant writing services. Learn more at bciburke.com/funding.

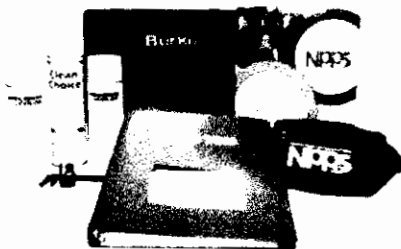
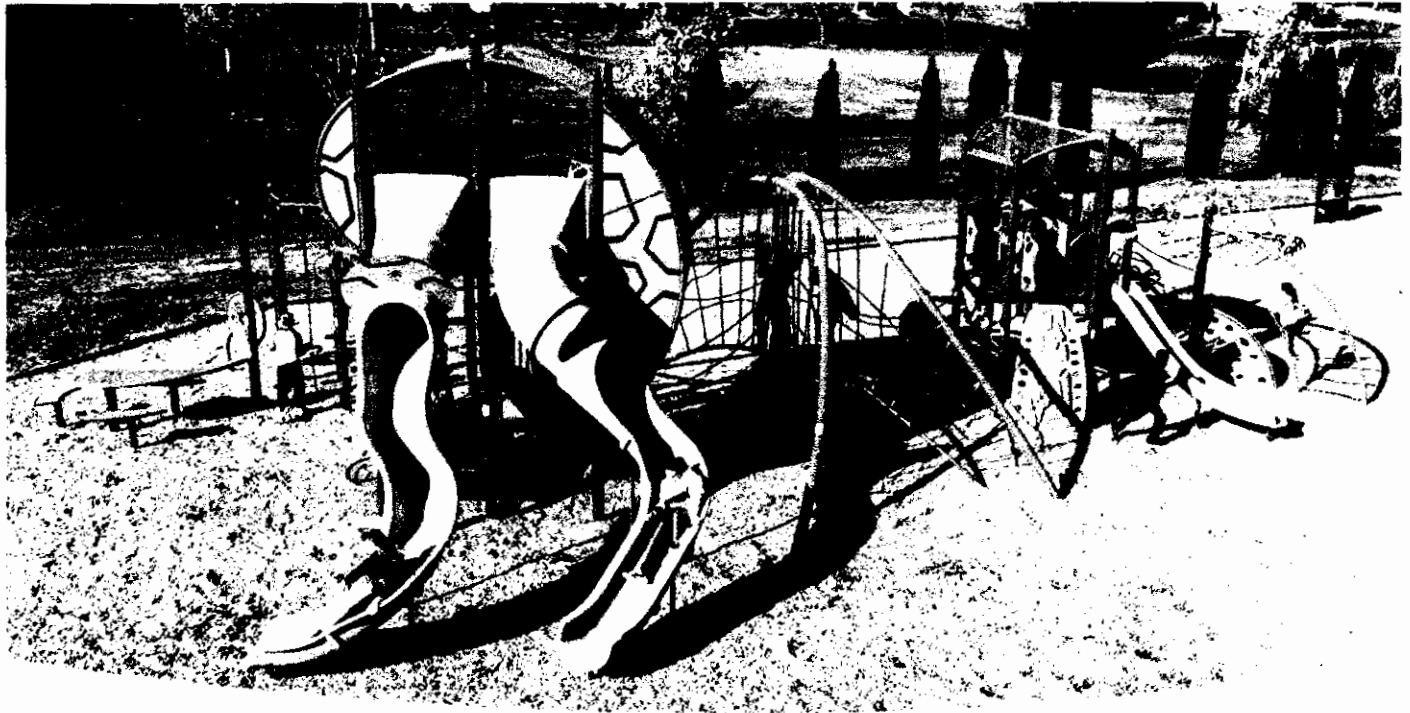

**FREE WITH EVERY BURKE
PLAY STRUCTURE PURCHASE**

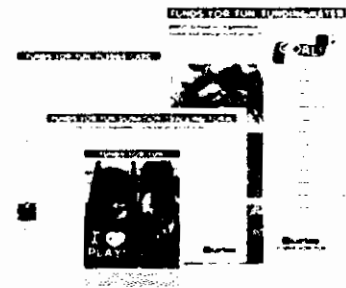

FREE FUNDRAISING TOOLS!

BCIBURKE.COM

Burke

800.266.1250

COOPERATIVE PURCHASING OPTIONS

PLAYGROUNDS WITHOUT ALL THE PAPERWORK

Purchasing with contracts may sound intimidating, but getting your community playspace doesn't need to be a painful process of writing specifications, issuing RFP's and jumping through hoops – it can be simplified – we promise! As you continue planning for your new commercial playground, review the Purchasing Contracts offered through our partners. Purchasing with one of these contracts simplifies the process and ensures the design and intent remain the same – serving as a place for your community to gather, grow and thrive.

EQUALIS GROUP

Equalis is an innovative cooperative purchasing organization that believes in the power of partnership and that when you work together you achieve more. The basic premise of the Equalis cooperative purchasing organization is to leverage the combined buying power of all members for better pricing and favorable contract terms. Equalis Group uses the lead agency model for competitively bid contracts, provides our participants the savings they expect and offers efficiencies and peace of mind within the procurement process. It is our mission to continuously improve the measurable and meaningful impact of cooperative services for everyone throughout the supply chain.

OMNIA PARTNERS

OMNIA Partners, Public Sector (Subsidiary National IPA) is the largest and most experienced organization in purchasing and supply chain management. Comprised of participants and suppliers in the public sector, we bring together industry-leading buying power and world-class suppliers to offer an extensive portfolio of competitively solicited and publicly awarded contracts and partnerships. OMNIA Partners is proud to offer more value and resources to state and local government, higher education, K-12 education and non-profits.

HGACBUY

Purchasing Burke playground equipment through HGACBuy gives your agency access to volume purchasing agreements and discounts, and there's no need to incur the time and expense of writing specs, issuing RFPs, advertising and evaluating bids. This can shorten your procurement cycle by months, while ensuring compliance with competitive bidding requirements.

SOURCEWELL

As a leader in cooperative purchasing, Sourcewell is passionate about helping members fulfill their public service missions. Sourcewell builds strong relationships with members and vendors to develop practical solutions together.

The easiest way to Join Our Movement is to call your local Representative at 800.266.1250 or visit bciburke.com/rep. Our passion is bringing play to communities like yours and we can't wait to help you get started!



Contract # 611821-BUR



FEATURED PLAY EVENTS



Konnection™ Swing

The Konnection Swing promotes intergenerational play, engagement and interaction when adults and children swing together. Children can also enjoy swinging together while advancing skills such as cooperation and teamwork.



4 Seat Rocker

Let's Rock! Burke's line of Rockers feature heavy-duty torsion springs and available in 2 Seat, 4 Seat and Standing versions. Rock your playground with these awesome freestanding basics events!

DESIGN SUMMARY

Innovative Playgrounds is very pleased to present this proposal for consideration for the Hollis M. Stewart Children's Park Area 1 located in Wrightwood. BCI Burke Company, LLC has been providing recreational playground equipment for over 90 years and has developed the right mix of world-class capabilities to meet the initial and continuing needs of Wrightwood Community Services District. We believe our proposal will meet or exceed your project's requirements and will deliver the greatest value to you.

The following is a summary of some of the key elements of our proposal:

- Project Name: Hollis M. Stewart Children's Park Area 1
- Project Number: 513-136825-6
- User Capacity: 11
- Age Groups: Ages 2-5 years, 5-12 years
- Dimensions: 50' 2" x 45' 0"
- Designer Name: Pa Der Vang

Innovative Playgrounds has developed a custom playground configuration based on the requirements as they have been presented for the Hollis M. Stewart Children's Park Area 1 playground project. Our custom design will provide a safe and affordable playground environment that is aesthetically pleasing, full of fun for all users and uniquely satisfies your specific requirements. In addition, proposal # 513-136825-6 has been designed with a focus on safety, and is fully compliant with ASTM F1487 and CPSC playground safety standards.

We invite you to review this proposal for the Hollis M. Stewart Children's Park Area 1 playground project and to contact us with any questions that you may have.

Thank you in advance for giving us the opportunity to make this project a success.

INFORMATION
MINIMUM FALL ZONE
SURFACED WITH
RESILIENT MATERIAL
AREA

1458 SQ. FT.

PERIMETER

255 FT.

STRUCTURE SIZE

50' 2" x 45' 0"

STRUCTURE IS DESIGNED
FOR CHILDREN AGES:

6-23 MONTH OLDS

X 2-5 YEAR OLDS

X 5-12 YEAR OLDS

13+ YEAR OLDS



To verify product certification, visit www.ipema.org

The play components identified in this plan are IPEMA certified. The use and layout of these components conform to the requirements of ASTM F1487. To verify product certification, visit www.ipema.org

The space requirements shown here are to ASTM standards. Requirements for other standards may be different.

The use and layout of play components identified in this plan conform to the CPSC guidelines. U.S. CPSC recommends the separation of age groups in playground layouts.

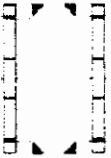

SCALE IN FEET
0 5 10

50'-1 1/2"

45'

WARNING!

ADDITIONAL SAFETY SURFACING MATERIAL IS REQUIRED BEYOND AND AROUND THIS EQUIPMENT.

FOR SLIDE FALL ZONE SURFACING AREA SEE CPSC's Handbook for Public Playground Safety.

PLATFORM HEIGHTS ARE IN INCHES ABOVE RESILIENT MATERIAL.

ADA ACCESSIBILITY GUIDELINE (ADAAG CONFORMANCE)

NUMBER OF PLAY EVENTS	7
NUMBER OF ELEVATED PLAY EVENTS	0
NUMBER OF ELEVATED PLAY EVENTS ACCESSIBLE BY RAMP	0
NUMBER OF ELEVATED PLAY EVENTS ACCESSIBLE BY TRANSFER SYSTEM	0
NUMBER OF ELEVATED PLAY EVENTS ACCESSIBLE BY RAMP OR TRANSFER SYSTEM	0
NUMBER OF GROUND LEVEL PLAY EVENTS	7
NUMBER OF TYPES OF GROUND LEVEL PLAY EVENTS	7

Burke

SERIES: Basics

SITE PLAN

DRAWN BY: Pa Der Vang

Hollis M. Stewart Children's Park Area 1

6059 Pine St.

Wrightwood, CA 92397

April 20, 2022

Innovative Playgrounds

513-136825-6

ITEM	COMP	DESCRIPTION
1	550-0112	BELT SEAT, 8' PAIR, STD CHAIN
2	550-0171	FREEDOM SWING SEAT, 8' BEAM
3	550-0191	KONNECTION SWING
4	550-0201	SINGLE POST SWING ASSEMBLY
5	550-0202	SINGLE POST SWING ADD-ON 5'
6	570-0053	4 SEAT ROCKER
7	580-0174	8' PVC TRADITIONAL BENCH W/
8	580-1013	8' PVC TRADITIONAL PICNIC TABLE
9	580-1302	FS SIGN, CUSTOM/CUSTOM

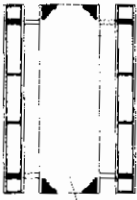

8



9

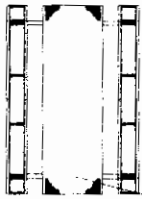

8



6

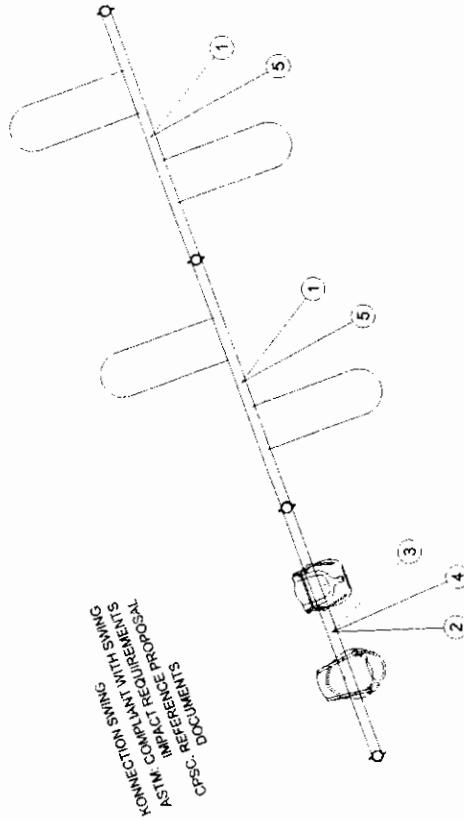

7



9

Burke

April 20, 2022

SERIES: Basics
 COMPONENT PLAN
 DRAWN BY: Pa Der Vang

Hollis M. Stewart Children's Park Area 1
 6059 Pine St.
 Wrightwood, CA 92397

Innovative Playgrounds
 513-136825-6

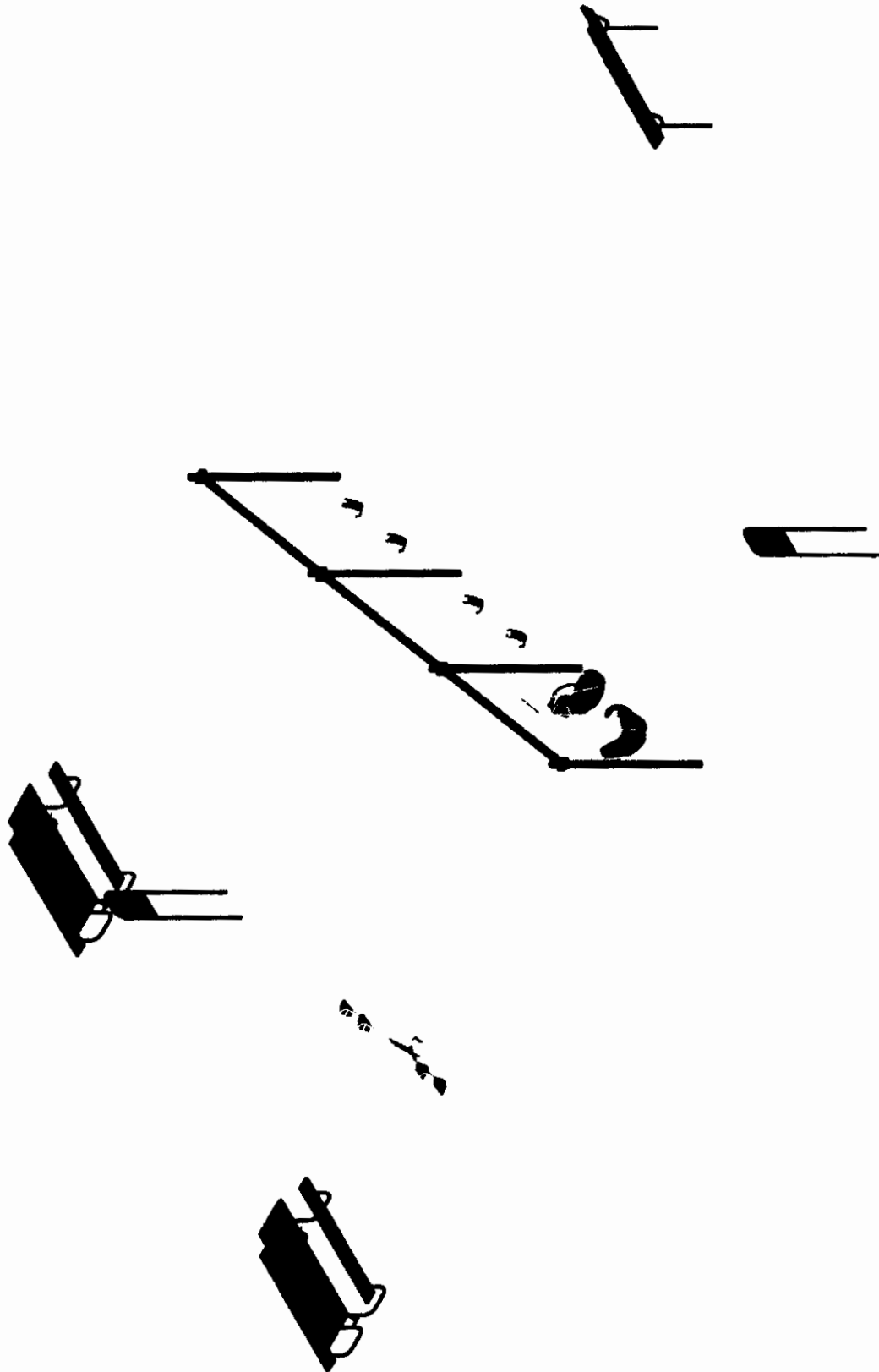

Burke

April 20, 2022

SERIES: Basics

Hollis M. Stewart Children's Park Area 1

Innovative Playgrounds

ISOMETRIC PLAN

6059 Pine St.

513-136825-6

DRAWN BY: Pa Der Vang

Wrightwood, CA 92397

BCI Burke Company, LLC PO Box 549 Fond du Lac, Wisconsin 54936-0549 Telephone 920-921-9220

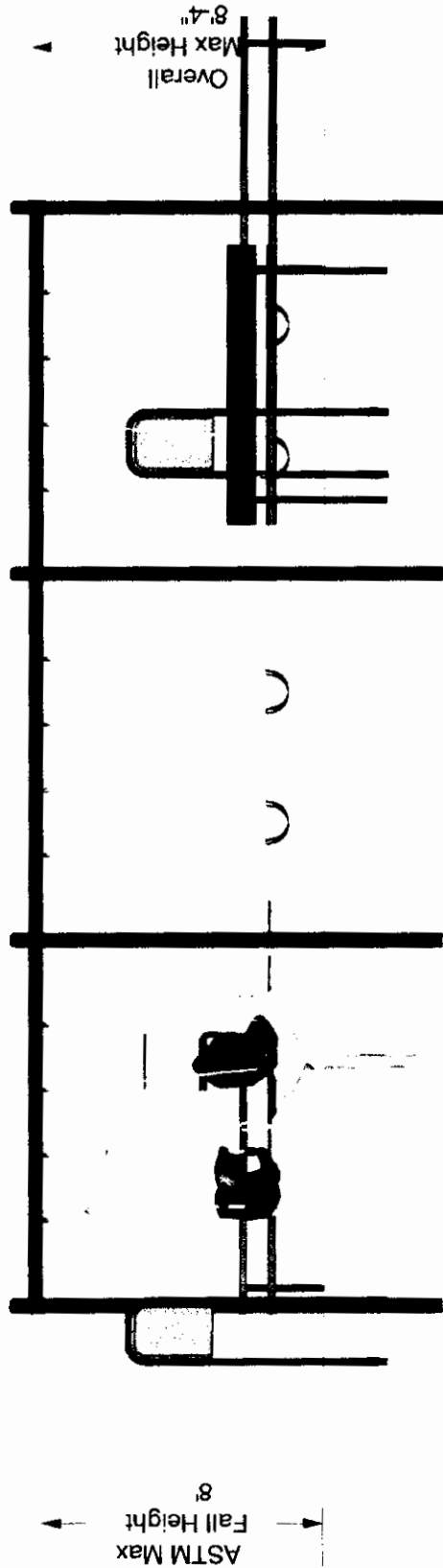

The protective surfacing for this design must accommodate the critical fall height.

Burke

April 20, 2022

SERIES: Basics
 ELEVATION PLAN
 DRAWN BY: Pa Der Vang

Hollis M. Stewart Children's Park Area 1
 6059 Pine St.
 Wrightwood, CA 92397

Innovative Playgrounds
 513-136825-6

FEATURED PLAY EVENTS



Large Boulder

Add to a playspace to create a natural outdoor play area for children and parents to gather, play and enjoy nature!



NaturePlay Rock Climber

Blend the wonder of nature into your playground by adding fun and adventure with Burke's Glass Fiber Reinforced Concrete (GFRC) Play Events!

DESIGN SUMMARY

Innovative Playgrounds is very pleased to present this proposal for consideration for the Hollis M. Stewart Park-Area 2 located in Wrightwood. BCI Burke Company, LLC has been providing recreational playground equipment for over 90 years and has developed the right mix of world-class capabilities to meet the initial and continuing needs of Wrightwood Community Services District. We believe our proposal will meet or exceed your project's requirements and will deliver the greatest value to you.

The following is a summary of some of the key elements of our proposal:

- Project Name: Hollis M. Stewart Park-Area 2
- Project Number: 513-136830-5
- User Capacity: 28
- Age Groups: Ages 5-12 years
- Dimensions: 20' 0" x 48' 8"
- Designer Name: Pa Der Vang

Innovative Playgrounds has developed a custom playground configuration based on the requirements as they have been presented for the Hollis M. Stewart Park-Area 2 playground project. Our custom design will provide a safe and affordable playground environment that is aesthetically pleasing, full of fun for all users and uniquely satisfies your specific requirements. In addition, proposal # 513-136830-5 has been designed with a focus on safety, and is fully compliant with ASTM F1487 and CPSC playground safety standards.

We invite you to review this proposal for the Hollis M. Stewart Park-Area 2 playground project and to contact us with any questions that you may have.

Thank you in advance for giving us the opportunity to make this project a success.

INFORMATION
 MINIMUM FALL ZONE
 SURFACED WITH
 RESILIENT MATERIAL
 AREA

648 SQ.FT.

PERIMETER
 133 FT.

STRUCTURE SIZE

20' 0" x 48' 8"

STRUCTURE IS DESIGNED
 FOR CHILDREN AGES:

6-23 MONTH OLDS

2-5 YEAR OLDS

X 5-12 YEAR OLDS

13 + YEAR OLDS



To verify product certification,
 visit www.ipema.org

The play components identified
 in this plan are IPEMA
 certified. The use and layout of
 these components conform to the
 requirements of ASTM F1487.
 To verify product certification
 visit www.ipema.org

The space requirements shown
 here are to ASTM standards.
 Requirements for other standards
 may be different.

The use and layout of play
 components identified in this plan
 conform to the CPSC guidelines.
 U.S. CPSC recommends the
 separation of age groups in
 playground layouts.

WARNING!

ACCESSIBLE SAFETY SURFACING MATERIAL IS REQUIRED BENEATH
 AND AROUND THIS EQUIPMENT
 FOR SLIDE FALL ZONE SURFACING AREA SEE CPSC's Handbook for
 Public Playground Safety
 PLATFORM HEIGHTS ARE IN INCHES ABOVE RESILIENT MATERIAL

Burke

SERIES: Specialty Items

SITE PLAN

DRAWN BY: Pa Der Vang

Hollis M. Stewart Park-Area 2

6059 Pine St.

Wrightwood, CA 92397

Innovative Playgrounds

513-136830-5

April 20, 2022

BCI Burke Company, LLC PO Box 549 Fond du Lac, Wisconsin 54936-0549 Telephone 920.921.9220

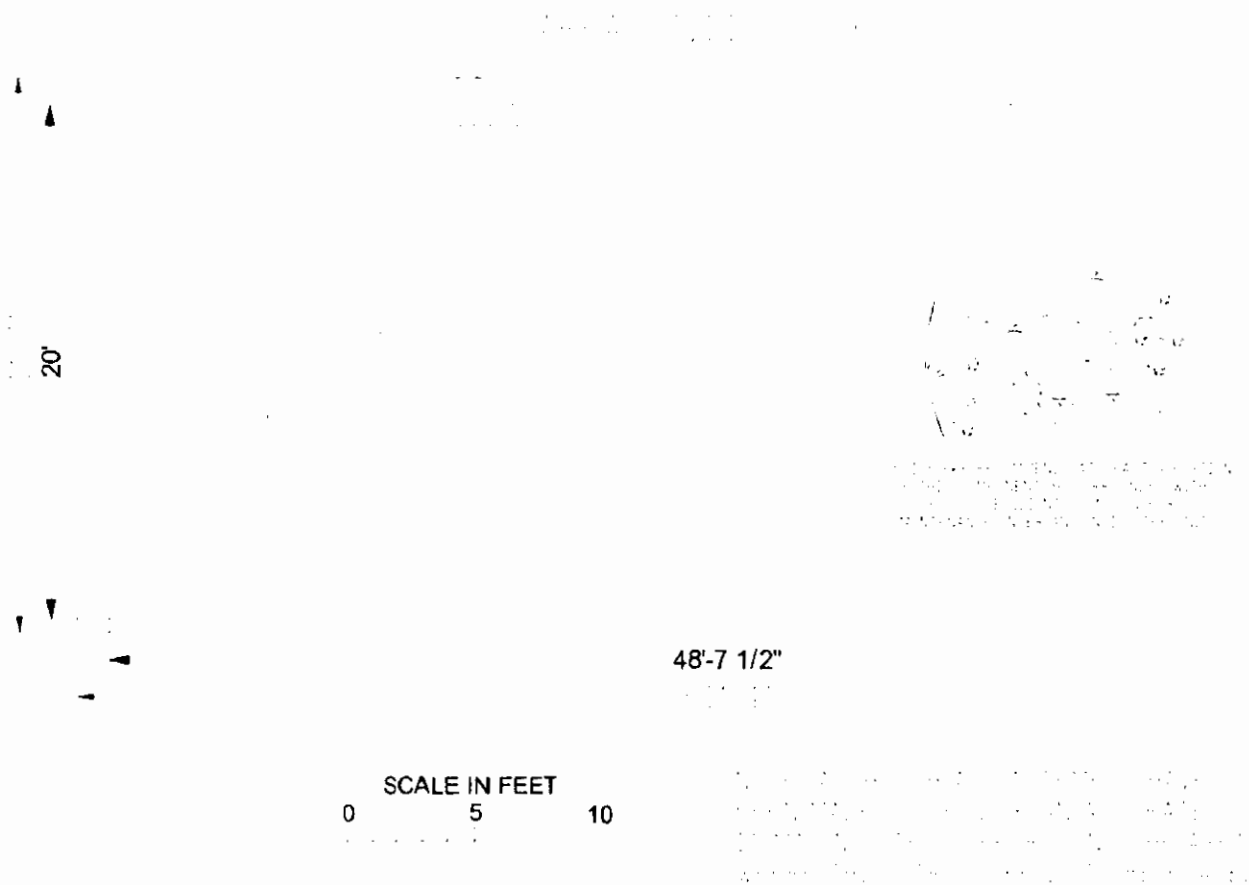

ADA ACCESSIBILITY GUIDELINE (ADAAG CONFORMANCE)

NUMBER OF PLAY EVENTS	2		
NUMBER OF ELEVATED PLAY EVENTS	0		
NUMBER OF ELEVATED PLAY EVENTS ACCESSIBLE BY RAMP	PROVIDED 0	REQUIRED 1	
NUMBER OF ELEVATED PLAY EVENTS ACCESSIBLE BY TRANSFER SYSTEM	PROVIDED 0	REQUIRED 0	
NUMBER OF ELEVATED PLAY EVENTS ACCESSIBLE BY RAMP OR TRANSFER SYSTEM	PROVIDED 0	REQUIRED 0	
NUMBER OF GROUND LEVEL PLAY EVENTS	PROVIDED 2	REQUIRED 2	
NUMBER OF TYPES OF GROUND LEVEL PLAY EVENTS	PROVIDED 2	REQUIRED 1	

ITEM	COMP	DESCRIPTION
1	560-0430	BOULDER NATURE PLAY LARGE
2	560-0560	NATURE PLAY ROCK CLIMBER



BCI SURVE RECOMMENDS AT LEAST A PORTION OF THIS COMPONENT BE SURROUNDED WITH LOOSE FILL RESILIENT TO ALLOW FOR MAINTENANCE UNDER AND INSIDE THE UNIT

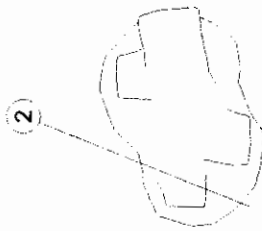

Burke

April 20, 2022

SERIES: Specialty Items

Hollis M. Stewart Park-Area 2

Innovative Playgrounds

COMPONENT PLAN

6059 Pine St.

513-136830-5

DRAWN BY: Pa Der Vang

Wrightwood, CA 92397

Overall
Max Height
8'-11"



ASTM Max
Fall Height
8'-11"

The protective surfacing for this design must accommodate the critical fall height.

Burke

April 20, 2022

SERIES: Specialty Items

Hollis M. Stewart Park-Area 2

Innovative Playgrounds

ELEVATION PLAN

6059 Pine St.

513-136830-5

DRAWN BY: Pa Der Vang

Wrightwood, CA 92397

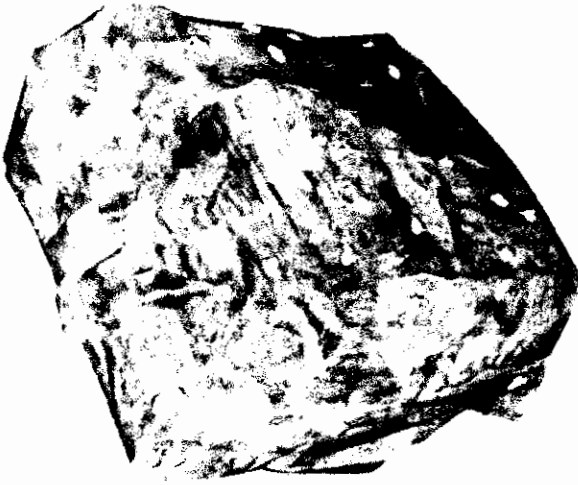

Burke

SERIES: Specialty Items
ISOMETRIC PLAN
DRAWN BY: Pa Der Vang

Hollis M. Stewart Park-Area 2
6059 Pine St.
Wrightwood, CA 92397

April 20, 2022

Innovative Playgrounds
513-136830-5

FEATURED PLAY EVENTS

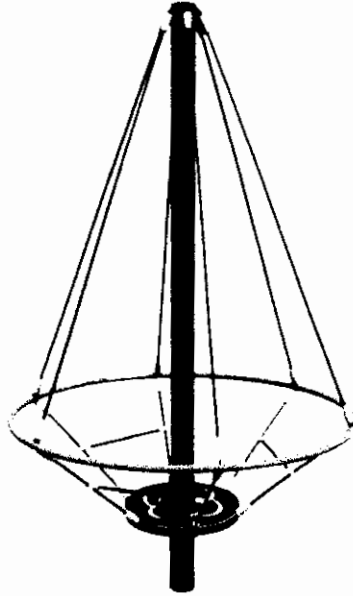

SPINETIC™

Spinetik is a multi-user spinner that offers children the opportunity to play together and work toward a common goal - an exciting spinning adventure on the playground!

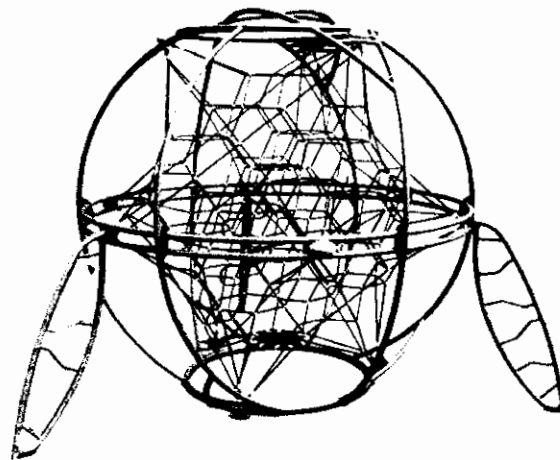

RopeVenture® Revolv

Create a true adventure with RopeVenture! Children can define their own climbing experience on this awe-inspiring rope system and create new routes every time they play!

DESIGN SUMMARY

Innovative Playgrounds is very pleased to present this proposal for consideration for the Hollis M. Stewart Park-Area 3 located in Wrightwood. BCI Burke Company, LLC has been providing recreational playground equipment for over 90 years and has developed the right mix of world-class capabilities to meet the initial and continuing needs of Wrightwood Community Services District. We believe our proposal will meet or exceed your project's requirements and will deliver the greatest value to you.

The following is a summary of some of the key elements of our proposal:

- Project Name: Hollis M. Stewart Park-Area 3
- Project Number: 513-136831-5
- User Capacity: 32
- Age Groups: Ages 5-12 years
- Dimensions: 35' 6" x 43' 2"
- Designer Name: Pa Der Vang

Innovative Playgrounds has developed a custom playground configuration based on the requirements as they have been presented for the Hollis M. Stewart Park-Area 3 playground project. Our custom design will provide a safe and affordable playground environment that is aesthetically pleasing, full of fun for all users and uniquely satisfies your specific requirements. In addition, proposal # 513-136831-5 has been designed with a focus on safety, and is fully compliant with ASTM F1487 and CPSC playground safety standards.

We invite you to review this proposal for the Hollis M. Stewart Park-Area 3 playground project and to contact us with any questions that you may have.

Thank you in advance for giving us the opportunity to make this project a success.

INFORMATION
MINIMUM FALL ZONE
SURFACED WITH
RESILIENT MATERIAL
AREA

873 SQ.FT

PERIMETER

151 FT.

STRUCTURE SIZE

35' 6" x 43' 2"

STRUCTURE IS DESIGNED
FOR CHILDREN AGES

6-23 MONTH OLDS

2-5 YEAR OLDS

X 5-12 YEAR OLDS

13+ YEAR OLDS



To verify product certification, visit www.ipema.org

The play components identified in this plan are IPEMA certified. The use and layout of these components conform to the requirements of ASTM F1487. To verify product certification, visit www.ipema.org

The space requirements shown here are to ASTM standards. Requirements for other standards may be different

The use and layout of play components identified in this plan conform to the CPSC guidelines. U.S. CPSC recommends the separation of age groups in playground layouts.

WARNING!

ACCESSIBILITY SAFETY SURFACING MATERIAL IS REQUIRED BENEATH AND AROUND THIS EQUIPMENT.
FOR SLIDE FALL ZONE SURFACING AREA SEE CPSC's Handbook for Public Playground Safety
PLATFORM HEIGHTS ARE IN INCHES ABOVE FINISH FLOOR MATERIAL

ADA ACCESSIBILITY GUIDELINE (ADAAG CONFORMANCE)

NUMBER OF PLAY EVENTS	5
NUMBER OF ELEVATED PLAY EVENTS ACCESSIBLE BY WALK	0
NUMBER OF ELEVATED PLAY EVENTS ACCESSIBLE BY "RAINFALL SYSTEM" OR "RAINFALL SYSTEM"	0
NUMBER OF ELEVATED PLAY EVENTS ACCESSIBLE BY "RAINFALL SYSTEM"	0
NUMBER OF GROUND LEVEL PLAY EVENTS	5
NUMBER OF TYPICAL GROUND LEVEL PLAY EVENTS	5

SCALE IN FEET
0 5 10

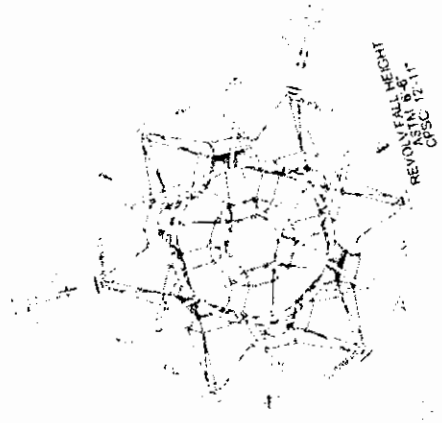

35'-6 1/2"

43'-2"

Burke

SERIES: Basics
SITE PLAN
DRAWN BY: Pa Der Vang

Hollis M. Stewart Park-Area 3
6059 Pine St.
Wrightwood, CA 92397

April 20, 2022
Innovative Playgrounds
513-136831-5

ITEM	COMP	DESCRIPTION
1	560-2587	ROPEVENTURE REVOLV
2	560-2596	REVOLV ATTACHMENT CLIMBER
3	560-2598	REVOLV ATTACHMENT CLIMBER
4	560-2600	REVOLV ATTACHMENT CLIMBER
5	560-2610	SPINETIC W/ SPEED LIMITER

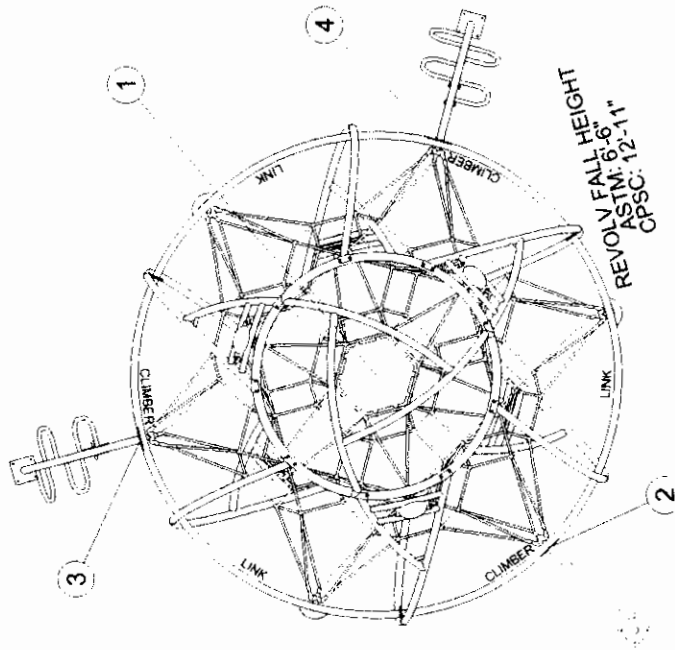
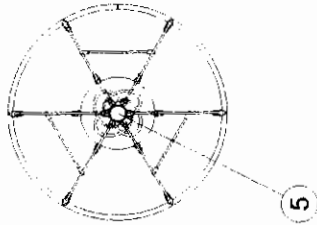

Burke

April 20, 2022

SERIES: Basics

Hollis M. Stewart Park-Area 3

Innovative Playgrounds

COMPONENT PLAN

6059 Pine St.

513-136831-5

DRAWN BY: Pa Der Vang

Wrightwood, CA 92397

Overall
Max Height
12'-11"

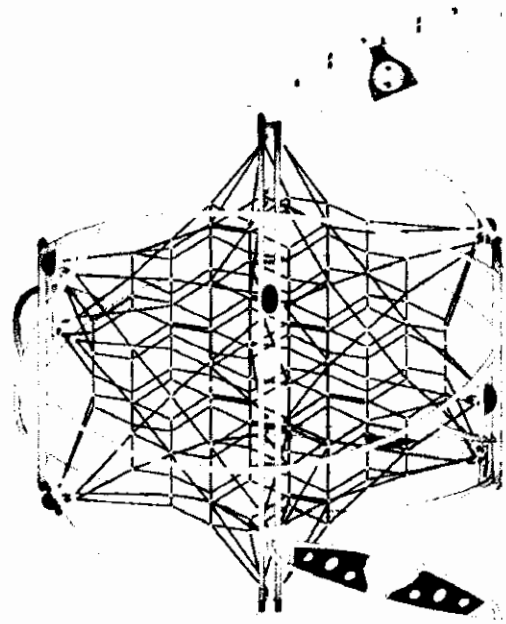
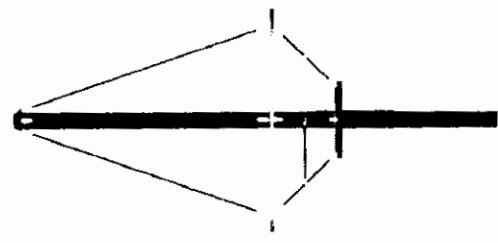

ASTM Max
Fall Height
6'-6"

Revolv Fall Height:
ASTM 6' 6"
CPSC 12' 11"

The protective surfacing for this design must accommodate the critical fall height.

Burke

April 20, 2022

SERIES: Basics
ELEVATION PLAN
DRAWN BY: Pa Der Vang

Hollis M. Stewart Park-Area 3
6059 Pine St.
Wrightwood, CA 92397

Innovative Playgrounds
513-136831-5

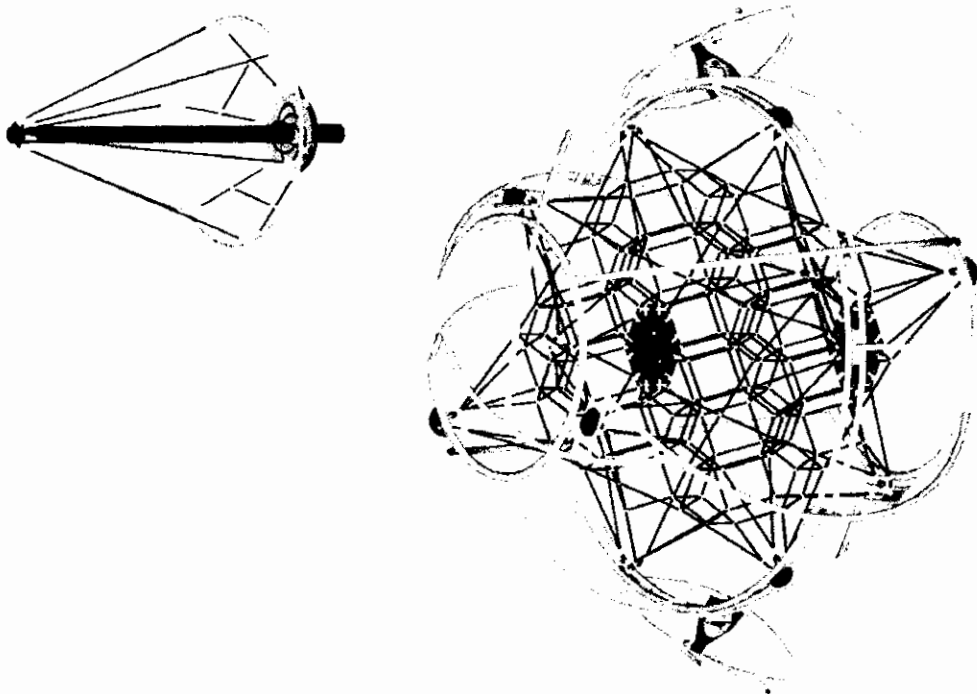

Burke

April 20, 2022

SERIES: Basics

Hollis M. Stewart Park-Area 3

Innovative Playgrounds

ISOMETRIC PLAN

6059 Pine St.

513-136831-5

DRAWN BY: Pa Der Vang

Wrightwood, CA 92397

BCI Burke Company, LLC PO Box 549 Fond du Lac, Wisconsin 54936-0549 Telephone 920-921-9220

FEATURED PLAY EVENTS

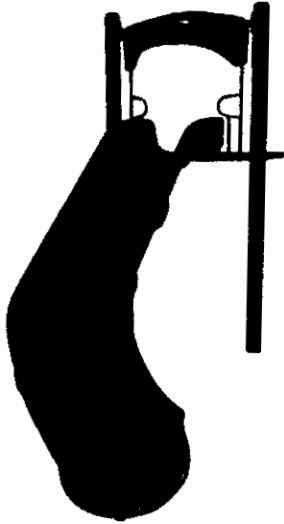

VIPER® SLIDE

The Viper Slide can't be tamed, but kids love trying! Viper's exciting twisty and fast serpentine action is guaranteed to generate incredible high-energy fun and safe, healthy play.

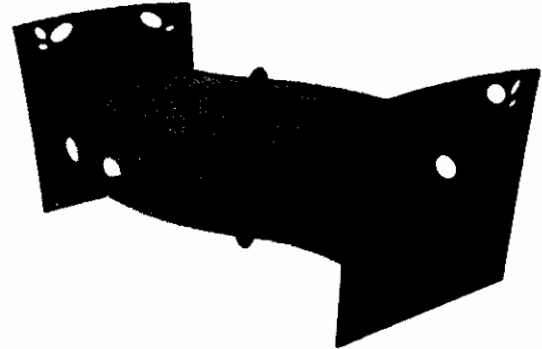

TUNNEL, 16" OFFSET TO GROUND

Our tubes & tunnels excite children's sense of exploration and adventure while improving gross motor skills and body strength.



CHARADE PANEL

Create the perfect play area for children with Burke's Interactive Play Panels. The play panels encourage exploration, interaction and develop fine-motor skills for children with all abilities.

FEATURED PLAY EVENTS

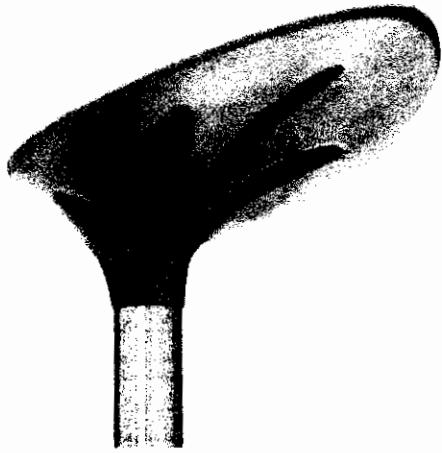

PETAL POST TOPPER

Post Toppers are a fun way to provide a finishing touch to any playground structure. Place one, two, three or more of these post toppers on your structure to create an aesthetic appeal or a fun, imaginative play concept.



Rain Wheel Panel

Incorporate musical exploration into your playground with Burke's Sound Garden. Real piano, drum and rain sounds provide creative and collaborative play opportunities for children of all abilities. The different music panels can be configured in multiple orientations to incorporate a variety of musical activities to provide hours of fun for all!



RockIt End Panel

RockIt creates the thrill, excitement and challenge of rock climbing in a realistic, yet safe, playground environment. Kids love a challenge, and RockIt challenges them with options to go around, through or over the mountain!

DESIGN SUMMARY

Innovative Playgrounds is very pleased to present this proposal for consideration for the Hollis M. Stewart Park-Area 4 located in Wrightwood. BCI Burke Company, LLC has been providing recreational playground equipment for over 90 years and has developed the right mix of world-class capabilities to meet the initial and continuing needs of Wrightwood Community Services District. We believe our proposal will meet or exceed your project's requirements and will deliver the greatest value to you.

The following is a summary of some of the key elements of our proposal:

- Project Name: Hollis M. Stewart Park-Area 4
- Project Number: 513-136832-6
- User Capacity: 29
- Age Groups: Ages 2-5 years
- Dimensions: 21' 5" x 30' 4"
- Designer Name: Pa Dcr Vang

Innovative Playgrounds has developed a custom playground configuration based on the requirements as they have been presented for the Hollis M. Stewart Park-Area 4 playground project. Our custom design will provide a safe and affordable playground environment that is aesthetically pleasing, full of fun for all users and uniquely satisfies your specific requirements. In addition, proposal # 513-136832-6 has been designed with a focus on safety, and is fully compliant with ASTM F1487 and CPSC playground safety standards.

We invite you to review this proposal for the Hollis M. Stewart Park-Area 4 playground project and to contact us with any questions that you may have.

Thank you in advance for giving us the opportunity to make this project a success.

INFORMATION
MINIMUM FALL ZONE
SURFACED WITH
RESILIENT MATERIAL
AREA

485 SQ.FT.

PERIMETER

85 FT.

SCALE IN FEET



STRUCTURE SIZE

21' 5" x 30' 4"

STRUCTURE IS DESIGNED
FOR CHILDREN AGES

6-23 MONTH OLDS

X 2-5 YEAR OLDS

5-12 YEAR OLDS

13 + YEAR OLDS



To verify product certification, visit www.ipema.org

The play components identified in this plan are IPEMA certified. The use and layout of these components conform to the requirements of ASTM F1487. To verify product certification visit www.ipema.org

The space requirements shown here are to ASTM standards. Requirements for other standards may be different.

The use and layout of play components identified in this plan conform to the CPSC guidelines. U.S. CPSC recommends the separation of age groups in playground layouts.

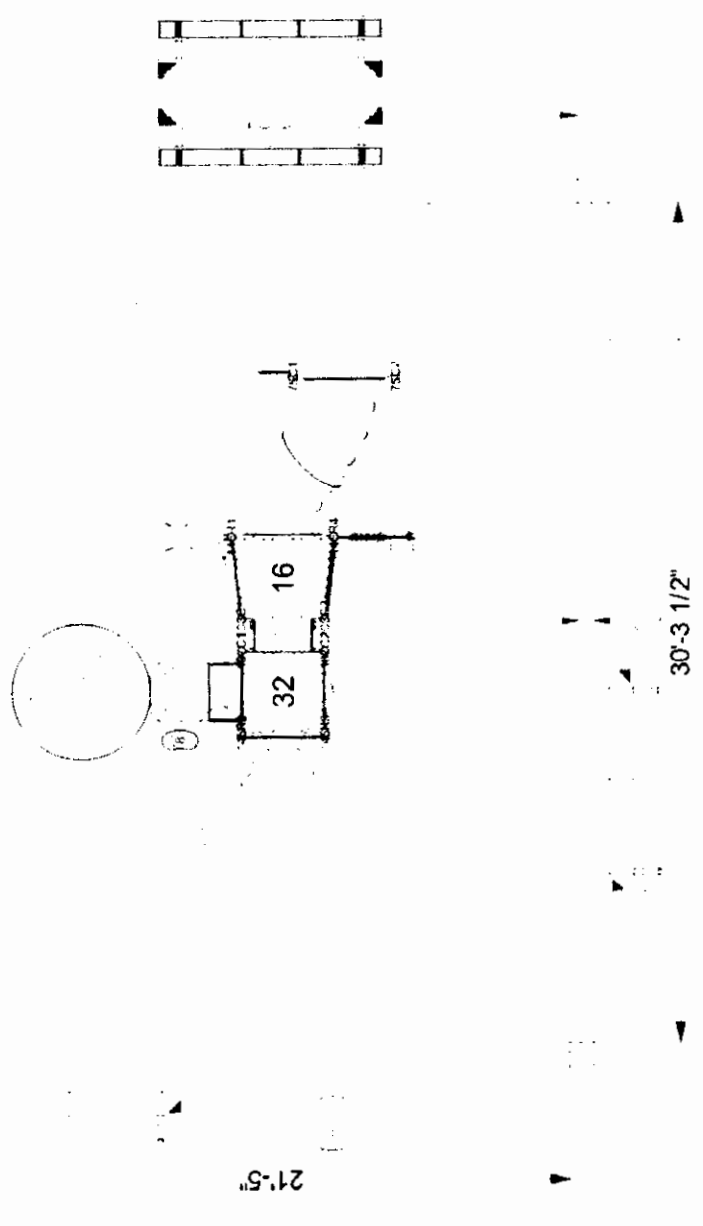

WARNING!

ACCESSIBLE SAFETY SURFACING MATERIAL IS REQUIRED BE NEATH AND AROUND THIS EQUIPMENT FOR SLIDE FALL ZONE SURFACING AREA SEE CPSC's Handbook for Public Playground Safety PLATFORM HEIGHTS ARE IN INCHES ABOVE REFERENT MATERIAL

ADA ACCESSIBILITY GUIDELINE (ADAAG CONFORMANCE)

NUMBER OF PLAY EVENTS	NUMBER OF PLAY EVENTS
NUMBER OF ELEVATED PLAY EVENTS	5
NUMBER OF ELEVATED PLAY EVENTS ACCESSIBLE BY RAMP	PROVIDED
NUMBER OF ELEVATED PLAY EVENTS ACCESSIBLE BY TRAYS OR SYSTEM	PROVIDED
NUMBER OF ELEVATED PLAY EVENTS ACCESSIBLE BY RAMP OR TRAYS OR SYSTEM	PROVIDED
NUMBER OF ORIGINAL LEVEL PLAY EVENTS	PROVIDED
NUMBER OF ORIGINAL LEVEL PLAY EVENTS	PROVIDED

Burke

SERIES: Basics, Synergy

SITE PLAN

DRAWN BY: Pa Der Vang

Hollis M. Stewart Park-Area 4

6059 Pine St.

Wrightwood, CA 92397

May 12, 2022

Innovative Playgrounds

513-136832-6

ITEM	COMP	DESCRIPTION
1	290-0102	SQUARE PLATFORM
2	290-0103	TRAPEZOID PLATFORM
3	290-0111	CLIMBER ENCLOSURE 2-5
4	290-0112	OFFSET ENCLOSURE 2-5
5	390-0106	18" TRANSITION STAIR W/BARR
6	390-0147	TRANSFER STATION, HANDRAIL
7	390-0154	TREE BRANCH CLIMBER 32"
8	490-0110	VIPER R 32
9	490-0145	PETAL POST TOPPER
10	490-0168	IMAGINATION DISCOVER VIPER
11	560-0540	ROCKIT END PANEL
12	580-0174	8' PVC TRADITIONAL BENCH W/
13	580-0305	RAIN WHEEL DRUM ELEMENT
14	580-1013	8' PVC TRADITIONAL PICNIC TA
15	580-1384	LIL NOVO BEAN STEP
16	590-0085	TUNNEL, 16" OFFSET TO GROUN
17	590-0140	SPINNER CRESCENT PANEL
18	590-0145	CHARADE PANEL, ABOVE PLATF
19	660-0137	ROCKIT ATTACHMENT POST 55"

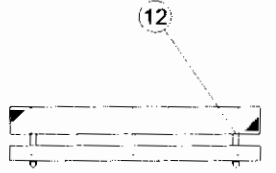
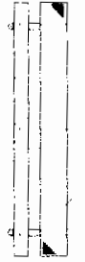
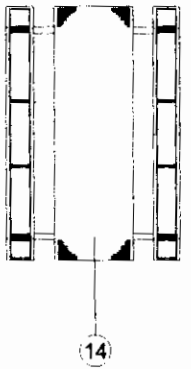
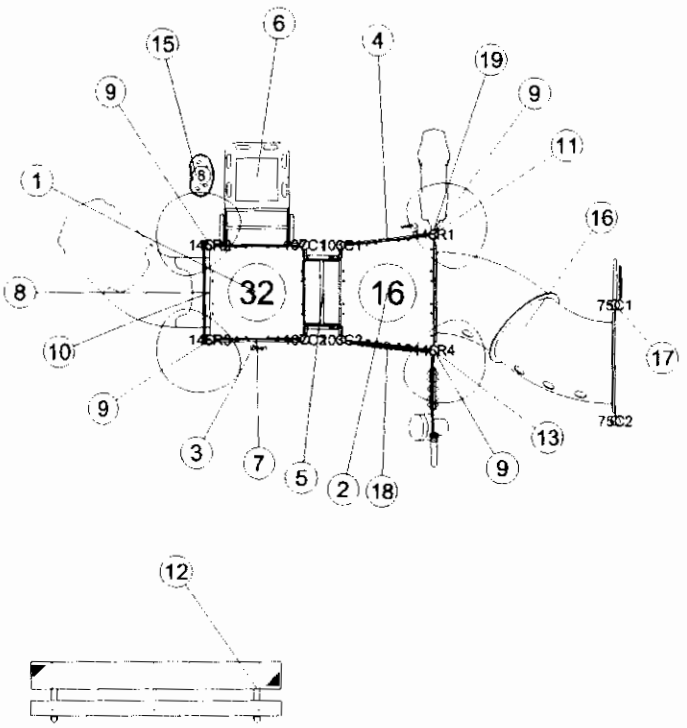

Burke

SERIES: Basics, Synergy
 COMPONENT PLAN
 DRAWN BY: Pa Der Vang

Hollis M. Stewart Park-Area 4
 6059 Pine St.
 Wrightwood, CA 92397

Innovative Playgrounds
 513-136832-6

May 12, 2022

BCI Burke Company, LLC PO Box 549 Fond du Lac, Wisconsin 54936-0549 Telephone 920-921-9720

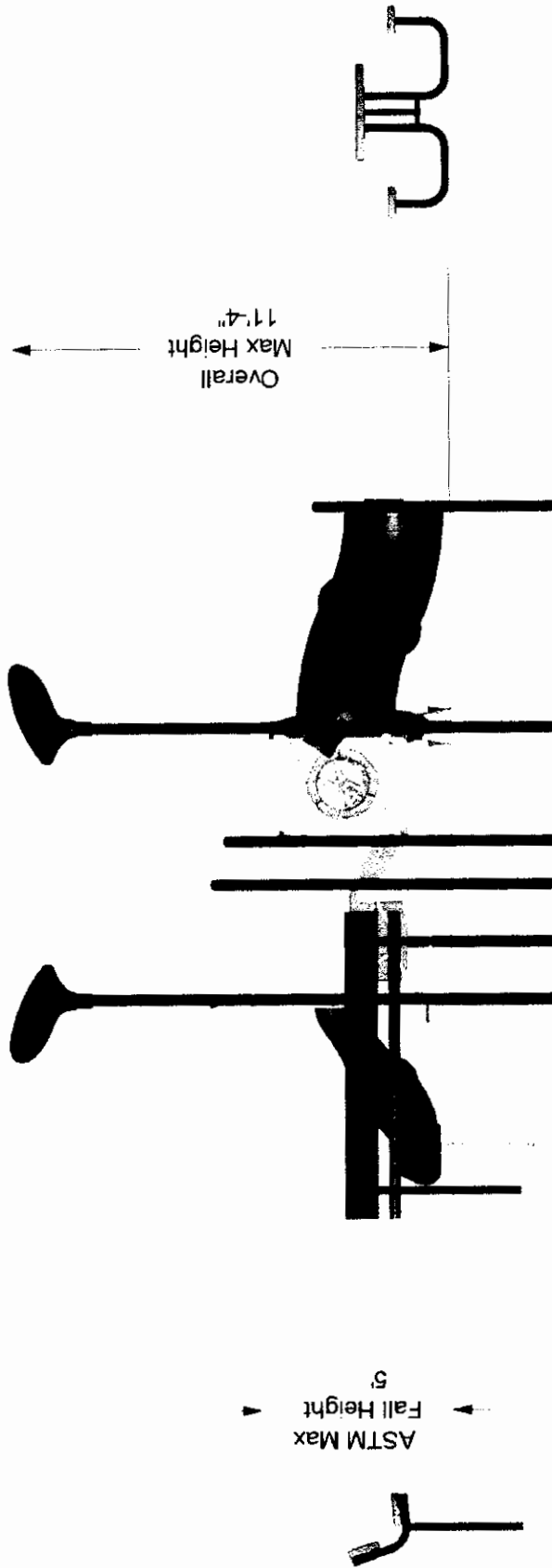

The protective surfacing for this design must accommodate the critical fall height.

Burke

SERIES: Basics, Synergy
 ELEVATION PLAN
 DRAWN BY: Pa Der Vang

Hollis M. Stewart Park-Area 4
 6059 Pine St.
 Wrightwood, CA 92397

Innovative Playgrounds
 513-136832-6

May 12, 2022

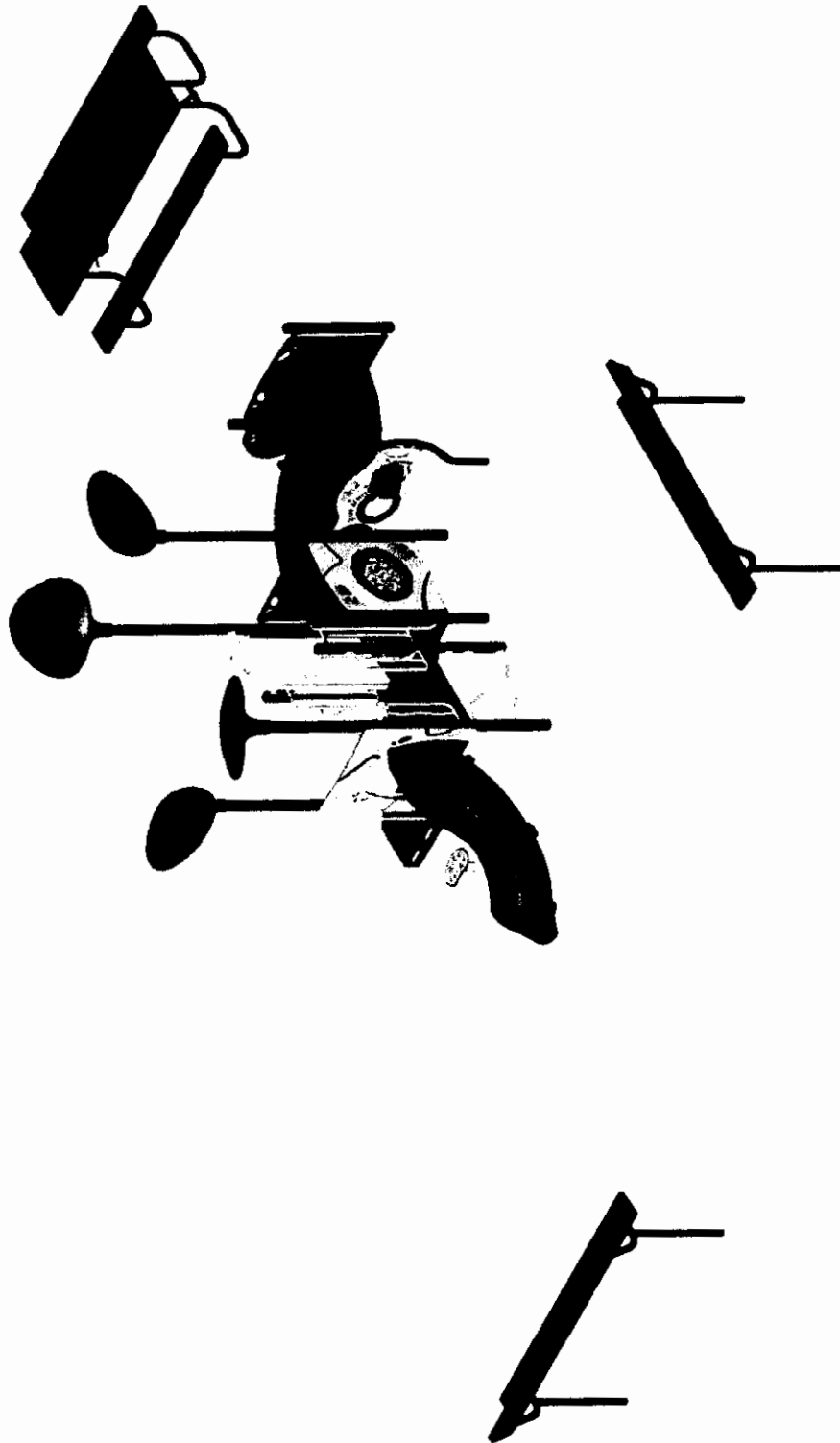

Burke

SERIES: Basics, Synergy

ISOMETRIC PLAN

DRAWN BY: Pa Der Vang

Hollis M. Stewart Park-Area 4

6059 Pine St.

Wrightwood, CA 92397

May 12, 2022

Innovative Playgrounds

513-136832-6

FEATURED PLAY EVENTS

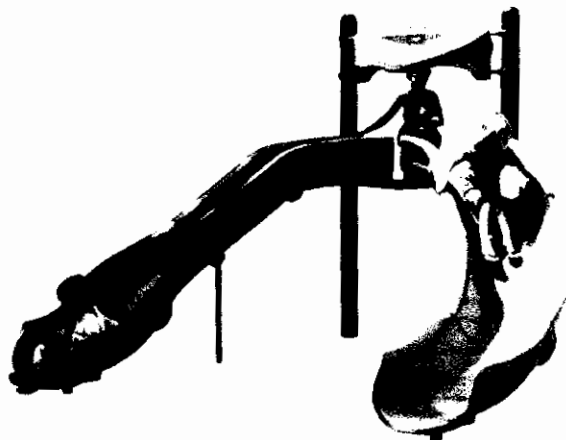

Viper Slide

The Viper Slide can't be tamed, but kids love trying! Viper's exciting twisty and fast serpentine action is guaranteed to generate incredible high-energy fun and safe, healthy play.

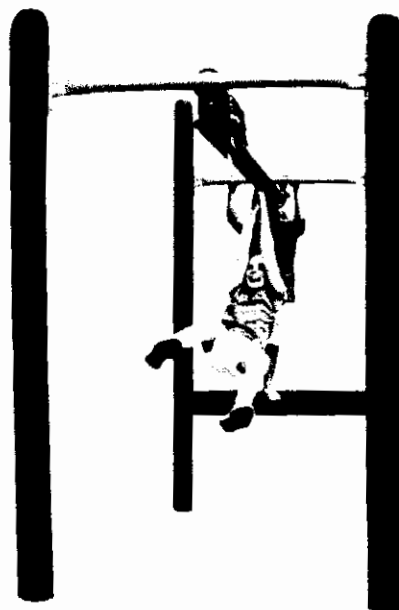

Kid Koaster

Overhead events build upper body strength and endurance, improve eye-hand coordination and elevate children's self-confidence.

DESIGN SUMMARY

Innovative Playgrounds is very pleased to present this proposal for consideration for the Hollis M. Stewart Park-Area 5 located in Wrightwood. BCI Burke Company, LLC has been providing recreational playground equipment for over 90 years and has developed the right mix of world-class capabilities to meet the initial and continuing needs of Wrightwood Community Services District. We believe our proposal will meet or exceed your project's requirements and will deliver the greatest value to you.

The following is a summary of some of the key elements of our proposal:

- Project Name: Hollis M. Stewart Park-Area 5
- Project Number: 513-138024-7
- User Capacity: 22
- Age Groups: Ages 2-5 years, 5-12 years
- Dimensions: 25' 2" x 53' 7"
- Designer Name: Pa Der Vang

Innovative Playgrounds has developed a custom playground configuration based on the requirements as they have been presented for the Hollis M. Stewart Park-Area 5 playground project. Our custom design will provide a safe and affordable playground environment that is aesthetically pleasing, full of fun for all users and uniquely satisfies your specific requirements. In addition, proposal # 513-138024-7 has been designed with a focus on safety, and is fully compliant with ASTM F1487 and CPSC playground safety standards.

We invite you to review this proposal for the Hollis M. Stewart Park-Area 5 playground project and to contact us with any questions that you may have.

Thank you in advance for giving us the opportunity to make this project a success.

INFORMATION
MINIMUM FALL ZONE
SURFACED WITH
RESILIENT MATERIAL
AREA

910 SQ. FT.

PERIMETER

164 FT.

STRUCTURE SIZE

25' 2" x 53' 7"

STRUCTURE IS DESIGNED
FOR CHILDREN AGES

6-23 MONTH OLDS

X 2-5 YEAR OLDS

X 5-12 YEAR OLDS

13+ YEAR OLDS



To verify product certification,
visit www.ipema.org

The play components identified
in this plan are IPEMA
certified. The use and layout of
these components conform to the
requirements of ASTM F1487.
To verify product certification,
visit www.ipema.org

The space requirements shown
here are to ASTM standards.
Requirements for other standards
may be different.

The use and layout of play
components identified in this plan
conform to the CPSC guidelines.
U.S. CPSC recommends the
separation of age groups in
playground layouts.

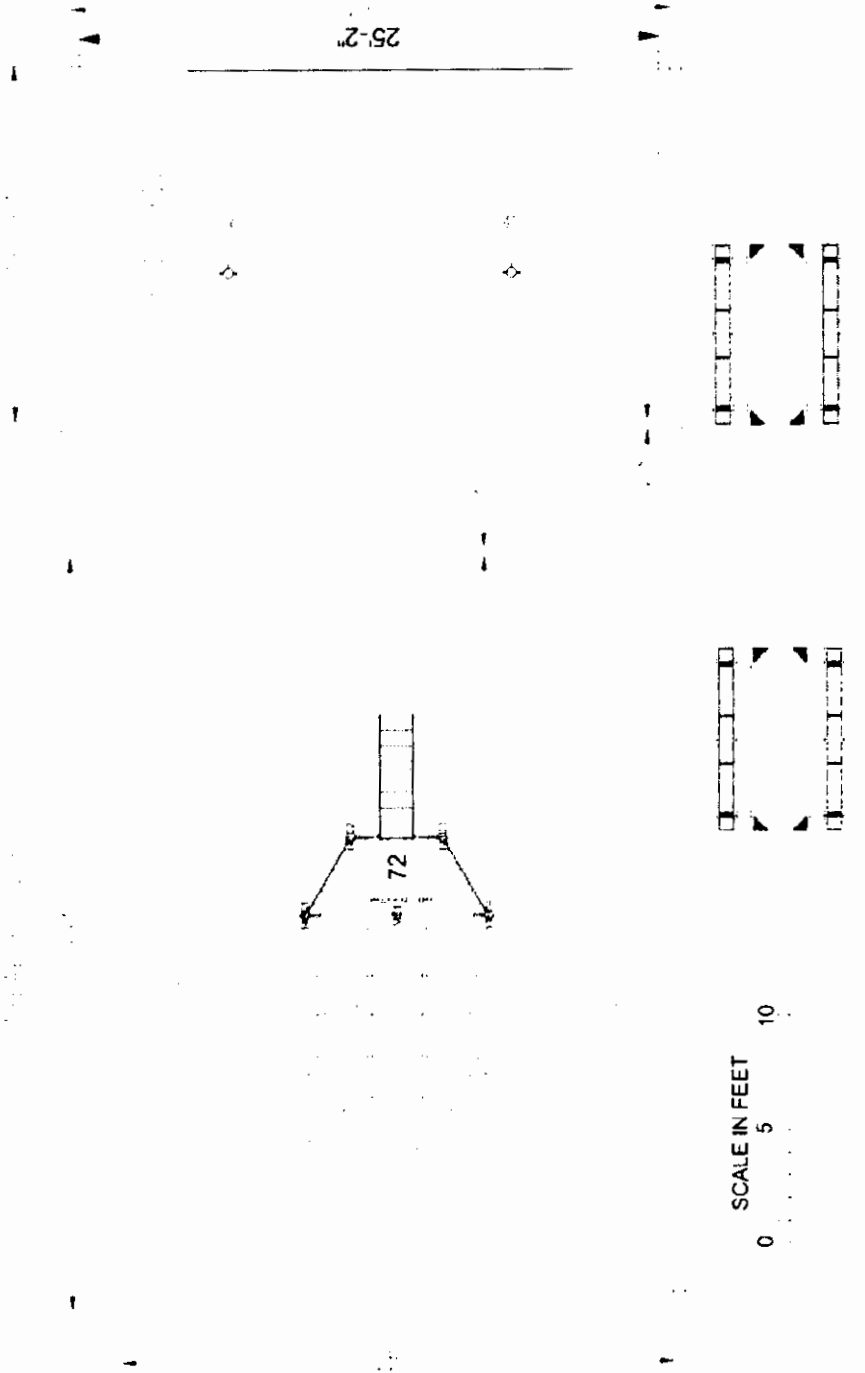

WARNING!

ACCESSIBLE SAFETY SURFACING MATERIAL IS REQUIRED BENEATH
AND AROUND THIS EQUIPMENT
FOR SLIDE FALL ZONE SURFACING AREA SEE CPSC's Handbook for
Public Playground Safety
PLATFORM HEIGHTS ARE IN INCHES ABOVE RESILIENT MATRIAL

ADA ACCESSIBILITY GUIDELINE (ADAAG CONFORMANCE)

	NUMBER OF PLAY EVENTS	?
NUMBER OF ELEVATED PLAY EVENTS ACCESSIBLE BY RAMP	PROVIDED: 0	REQUIRED: 0
NUMBER OF ELEVATED PLAY EVENTS ACCESSIBLE BY TRANSFER SYSTEM	PROVIDED: 0	REQUIRED: 0
NUMBER OF ELEVATED PLAY EVENTS ACCESSIBLE BY RAMP OR TRANSFER SYSTEM	PROVIDED: 1	REQUIRED: 1
NUMBER OF WHEELCHUR-ACCESSIBLE PLAY EVENTS	PROVIDED: 1	REQUIRED: 1

Burke

SERIES: Basics, Nucleus

SITE PLAN

DRAWN BY: Pa Der Vang

Hollis M. Stewart Park-Area 5

6059 Pine St.

Wrightwood, CA 92397

June 07, 2022

Innovative Playgrounds

513-138024-7

ITEM	COMP.	DESCRIPTION
1	270-0236	VIPER SLIDE HALF HEX PLATFO
2	370-0513	NARROW STAIRWAY 72"
3	470-0587	VIPER III RL 64-72
4	570-0394	PIPE WALL
5	580-1013	8" PVC TRADITIONAL PICNIC TABLE
6	670-0387	FS 12' SINGLE BEAM KID KOAST

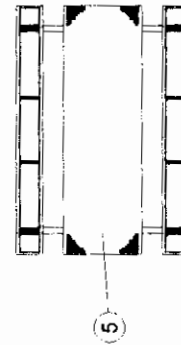
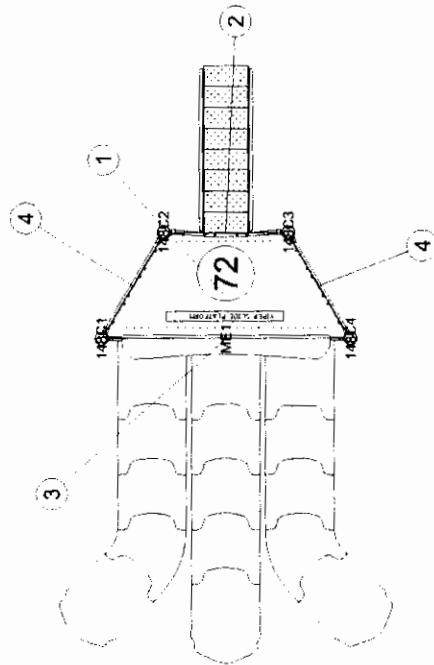
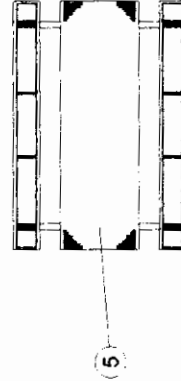

Burke

June 07, 2022

SERIES: Basics, Nucleus

Hollis M. Stewart Park-Area 5

Innovative Playgrounds

COMPONENT PLAN

6059 Pine St.

513-138024-7

DRAWN BY: Pa Der Vang

Wrightwood, CA 92397

BCI Burke Company, LLC PO Box 549 Fond du Lac, Wisconsin 54936-0549 Telephone 920-921-9220

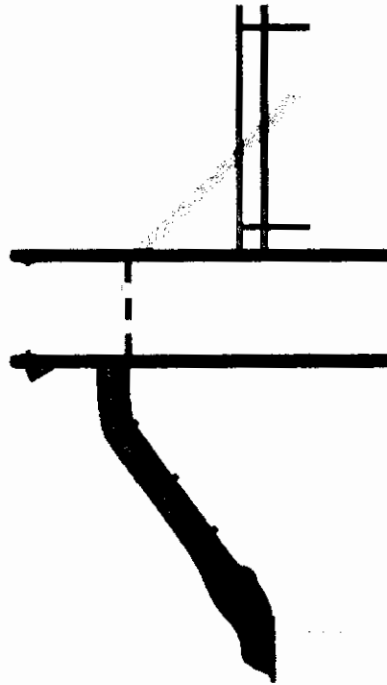
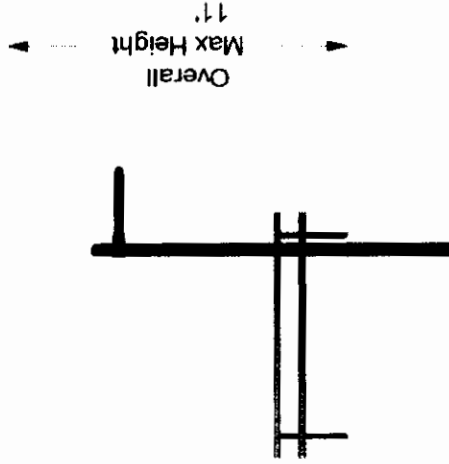

The protective surfacing for this design must accommodate the critical fall height.

Burke

June 07, 2022

SERIES: Basics, Nucleus
 ELEVATION PLAN
 DRAWN BY: Pa Der Vang

Hollis M. Stewart Park-Area 5
 6059 Pine St.
 Wrightwood, CA 92397

Innovative Playgrounds
 513-138024-7

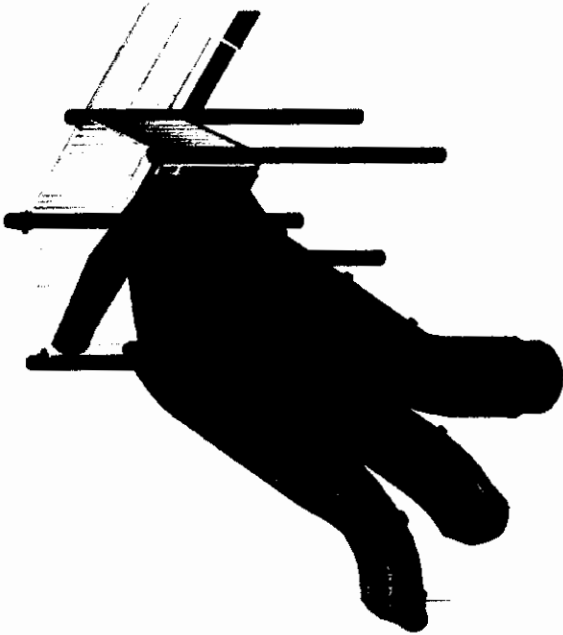
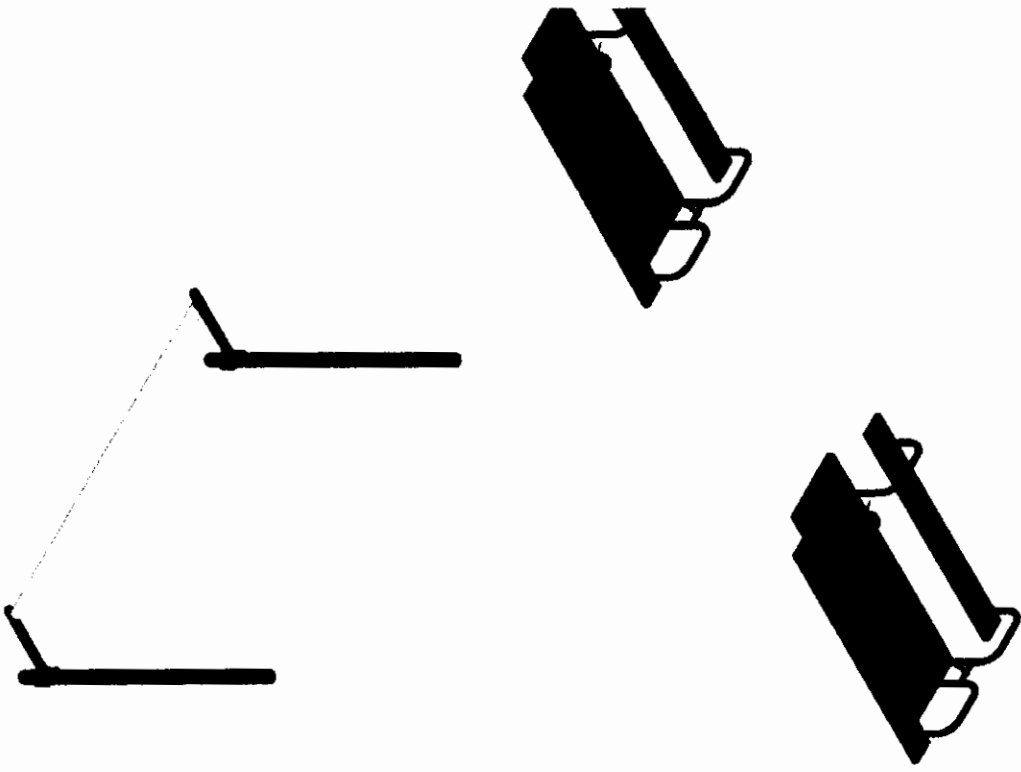

Burke

June 07, 2022

SERIES: Basics, Nucleus

Hollis M. Stewart Park-Area 5

Innovative Playgrounds

ISOMETRIC PLAN

6059 Pine St.

513-138024-7

DRAWN BY: Pa Der Vang

Wrightwood, CA 92397

BCI Burke Company, LLC PO Box 549 Fond du Lac, Wisconsin 54936-0549 Telephone 920-921-9220